

P-12507

S3654

28163

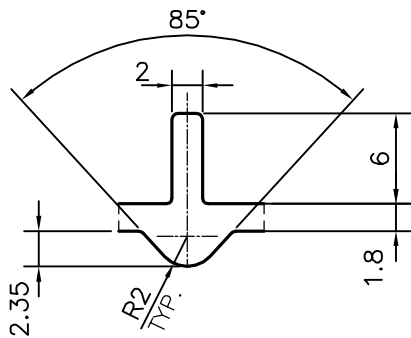
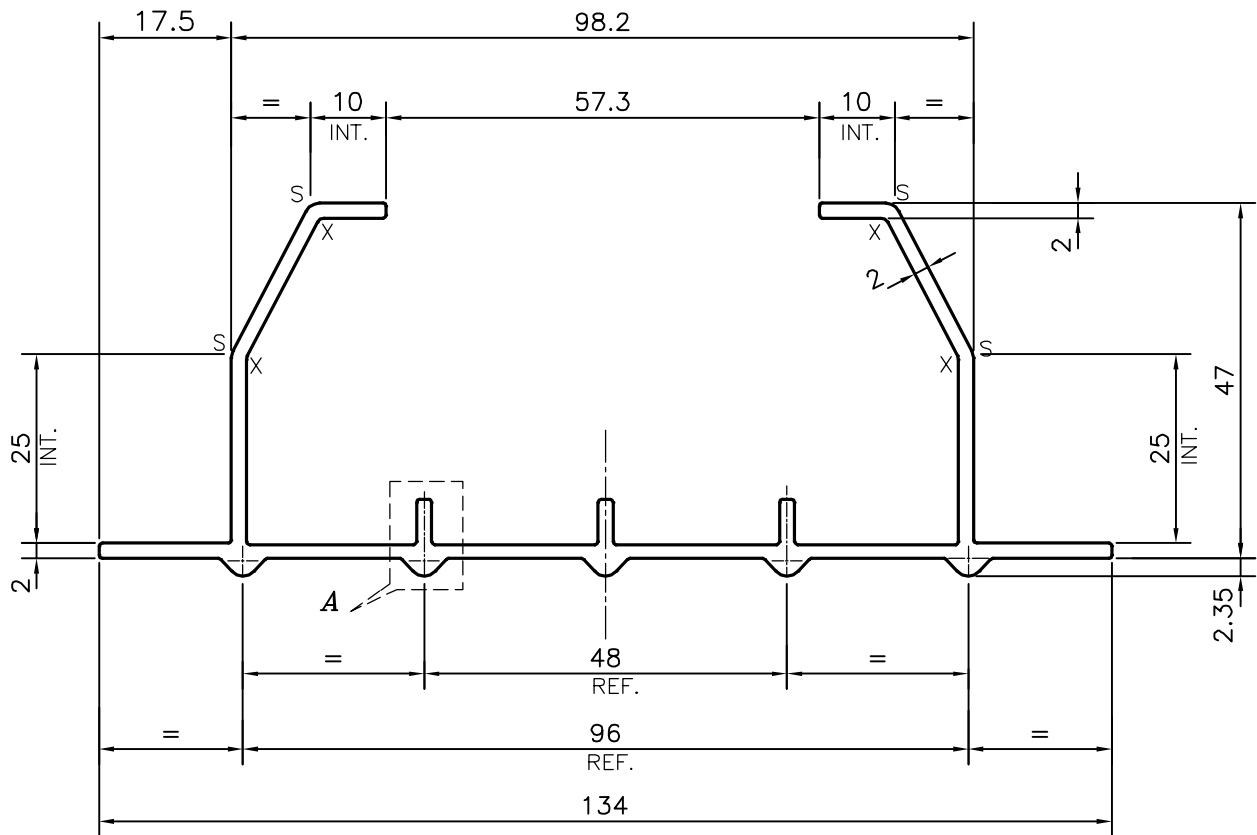

DETAIL OF "A"
SCALE :- 2:1

S = RADIUS 2 mm. (4 PLACES)
X = RADIUS 1 mm. (4 PLACES)



SYMBOL OF QUALITY
AN ISO 9001 COMPANY

JINDAL ALUMINIUM LTD.
BANGALORE-560073 (INDIA)

	NAME	DATE
DRAWN	PARVESH	02-02-2013
CHECKED		
APPROVED	J.N.RAI	09-02-2013

1. ALL DIMENSIONS ARE IN mm.
2. ROUND OFF ALL SHARP CORNERS WITH 0.40 mm.
3. TOLERANCES WILL BE AS PER IS:3965-1981 , UNLESS OTHERWISE SPECIFIED

SCALE	1:1
AREA mm ²	553.083
PERIMETER mm.	536.057
WEIGHT kg/m	1.493

PARTY'S NAME	PRESSTON ENGINEERING CORPORATION, BANGALORE
PARTY'S DRAWING No.	AS PER Auto CAD DRAWING
ALLOY & TEMPER	6063 T6
DESCRIPTION	INDUSTRIAL SECTION

DRAWING No.	SECTION No.
P-12507	-
S3654	S3654
28163	28163