

P-12508-1

S3655

28164

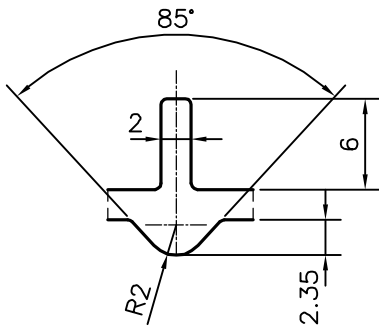
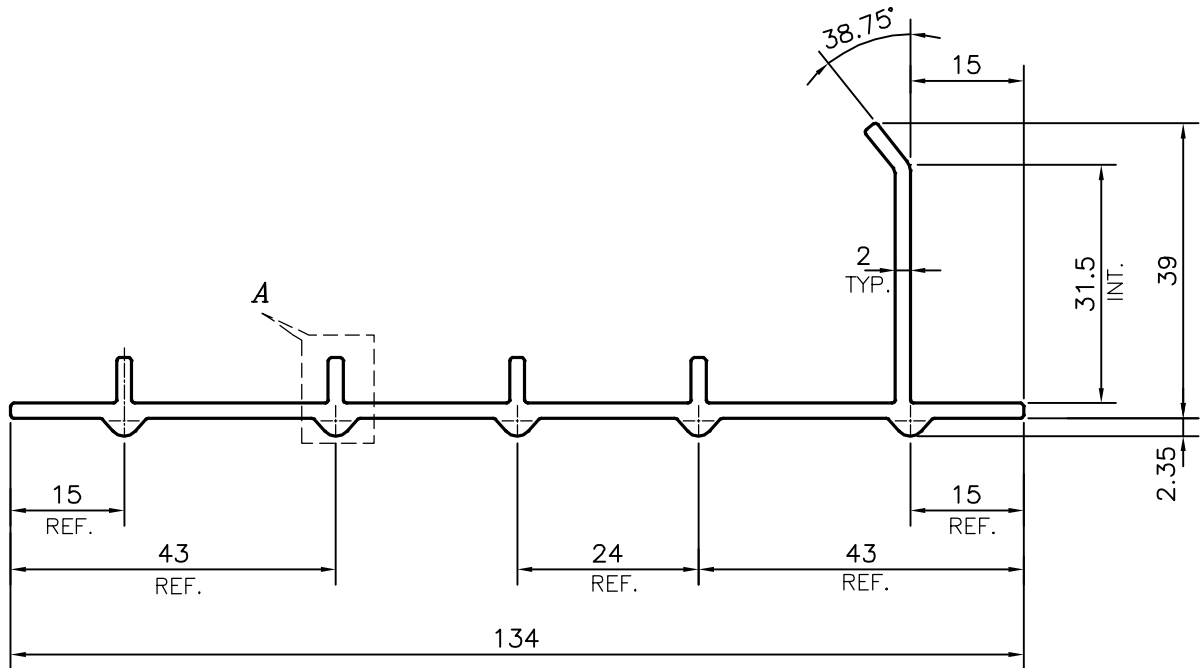

DETAIL OF "A"
SCALE :- 2:1



SYMBOL OF QUALITY
AN ISO 9001 COMPANY

JINDAL ALUMINIUM LTD.
BANGALORE-560073 (INDIA)

	NAME	DATE
DRAWN	PARVESH	04-02-2013
CHECKED		
APPROVED	J.N.RAI	09-02-2013
SCALE		1:1
AREA	mm ²	436.942
PERIMETER	mm.	401.031
WEIGHT	kg/m	1.18
DRAWING No.	SECTION No.	
P-12508-1	-	
S3655	S3655	
28164	28164	

1. ALL DIMENSIONS ARE IN mm.
2. ROUND OFF ALL SHARP CORNERS WITH 0.40 mm.
3. TOLERANCES WILL BE AS PER IS:3965-1981 , UNLESS OTHERWISE SPECIFIED

PARTY'S NAME	PRESSTON ENGINEERING CORPORATION, BANGALORE
PARTY'S DRAWING No.	AS PER Auto CAD DRAWING
ALLOY & TEMPER	6063 T6
DESCRIPTION	INDUSTRIAL SECTION