

P-12546

S3667

28172

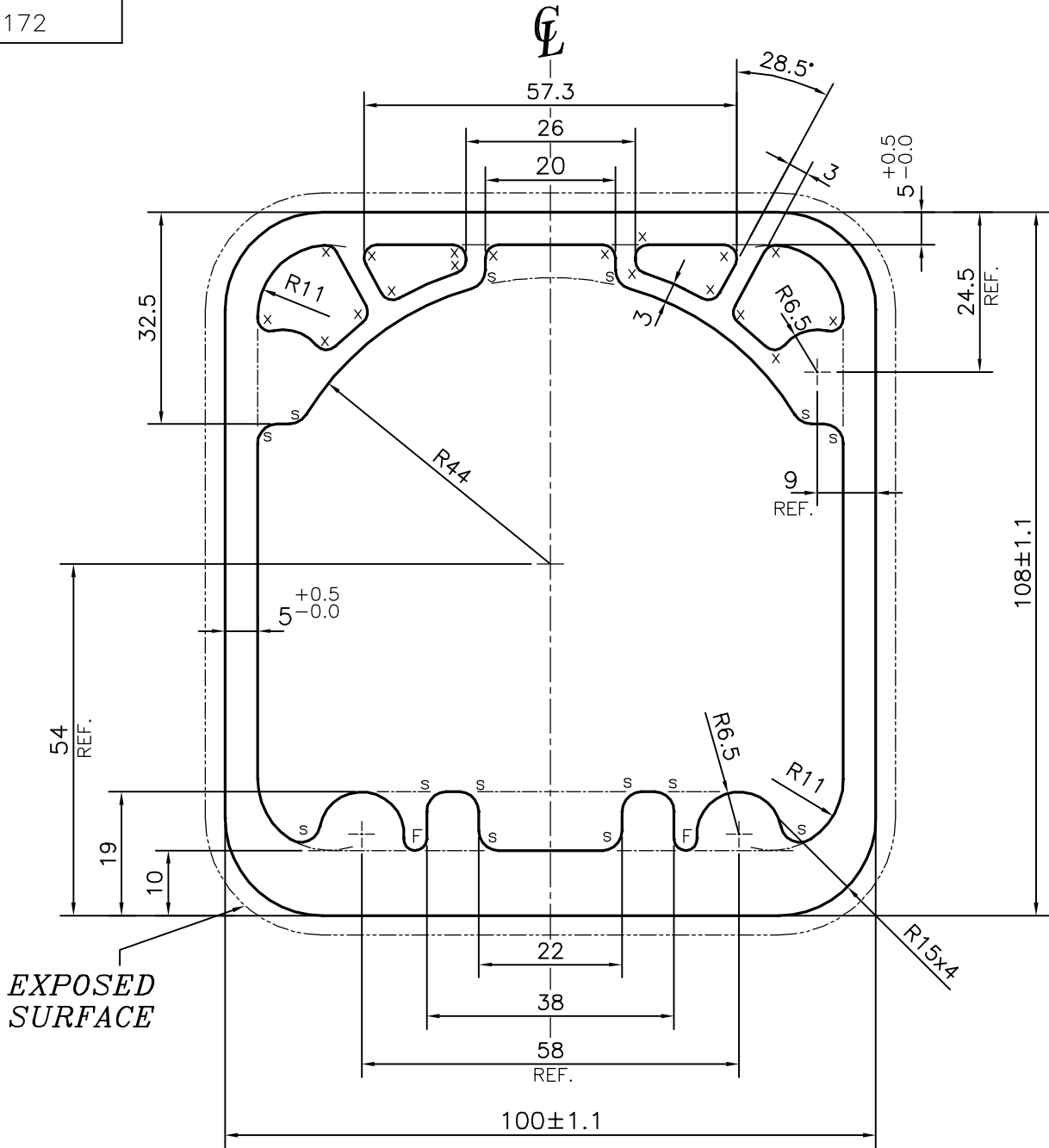

X = RADIUS 2 mm. (18 PLACES)  
 S = RADIUS 3 mm. (14 PLACES)  
 F = FULL RADIUS (2 PLACES)



SYMBOL OF QUALITY  
 AN ISO 9001 COMPANY

**JINDAL ALUMINIUM LTD.**  
 BANGALORE-560073 (INDIA)

	NAME	DATE
DRAWN	PARVESH	16-02-2013
CHECKED		
APPROVED	S.S.GARG	21-02-2013
SCALE		1:1
AREA mm <sup>2</sup>		3233.214
PERIMETER mm.		390.248
WEIGHT kg/m		8.73
DRAWING No.	SECTION No.	
P-12546	-	
S3667	S3667	
28172	28172	

1. ALL DIMENSIONS ARE IN mm.
2. ROUND OFF ALL SHARP CORNERS WITH 0.40 mm.
3. TOLERANCES WILL BE AS PER IS:6477-1983 , UNLESS OTHERWISE SPECIFIED

PARTY'S NAME	PLUS & PLUS, POUNDICHERY
PARTY'S DRAWING No.	AP-50101
ALLOY & TEMPER	6063 T6
DESCRIPTION	MEDICAL EQUIPMENT SECTION