

P-15550-1

28212

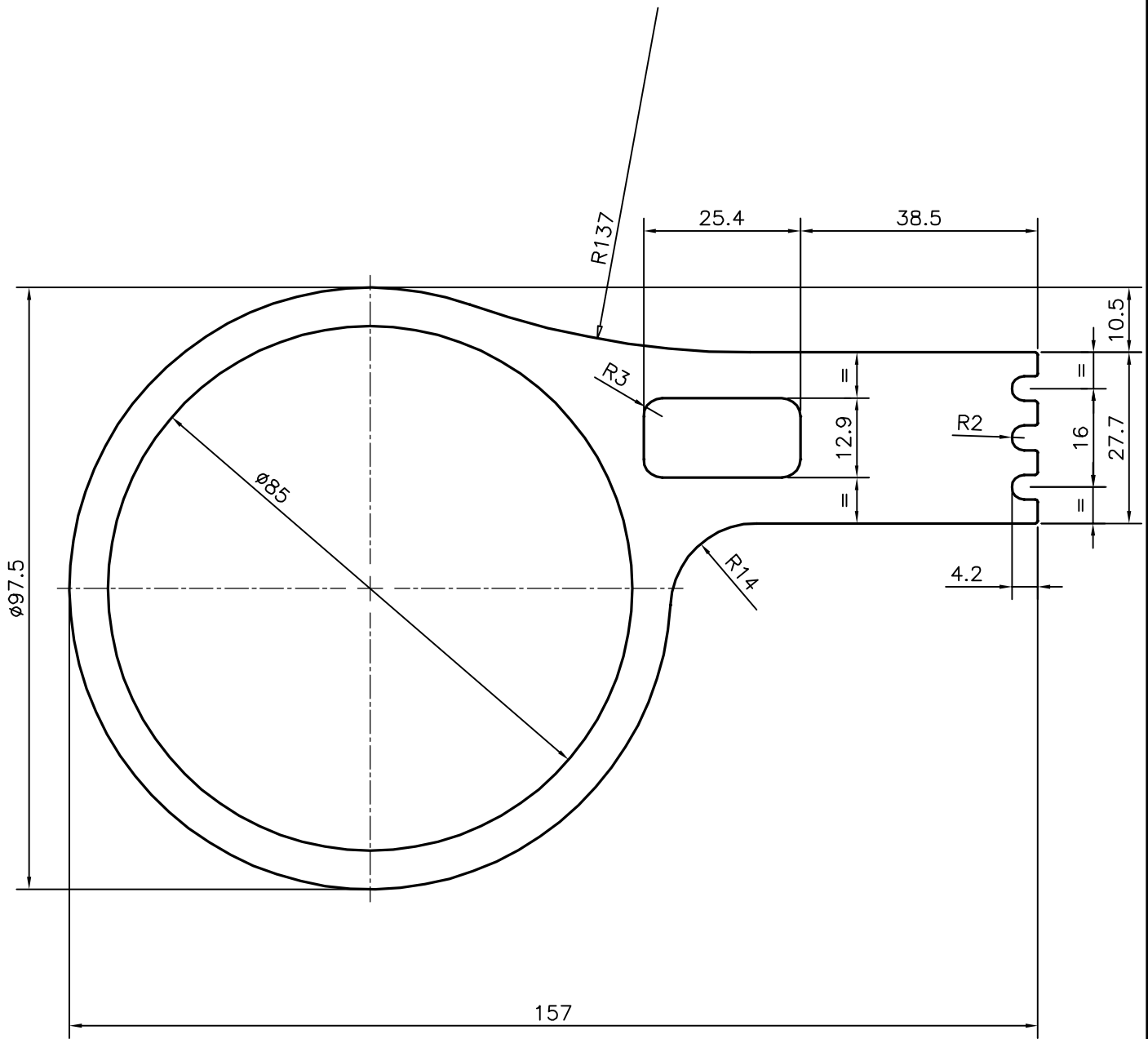

SYMBOL OF QUALITY
AN ISO 9001 COMPANY

JINDAL ALUMINIUM LTD.
BANGALORE-560073 (INDIA)

	NAME	DATE
DRAWN	J.P.KAUSHIK	01-02-2016
CHECKED		
APPROVED	B. NATARAJ	05-02-2016
SCALE		1:1
AREA mm ²		3384.24
PERIMETER mm.		449.676
WEIGHT kg/m		9.137
DRAWING No.	SECTION No.	
P-15550-1	-	
28212	28212	

1. ALL DIMENSIONS ARE IN mm.
2. ROUND OFF ALL SHARP CORNERS WITH 0.40 mm.
3. TOLERANCES WILL BE AS PER, IS:6477-1983 UNLESS OTHERWISE SPECIFIED

PARTY'S NAME	GENERAL CATEGORY, BANGALORE MARKET
PARTY'S DRAWING No.	AS PER SAMPLE
ALLOY & TEMPER	6005 T6
DESCRIPTION	MISC. SECTION