

P-14927-1

S4559

28218

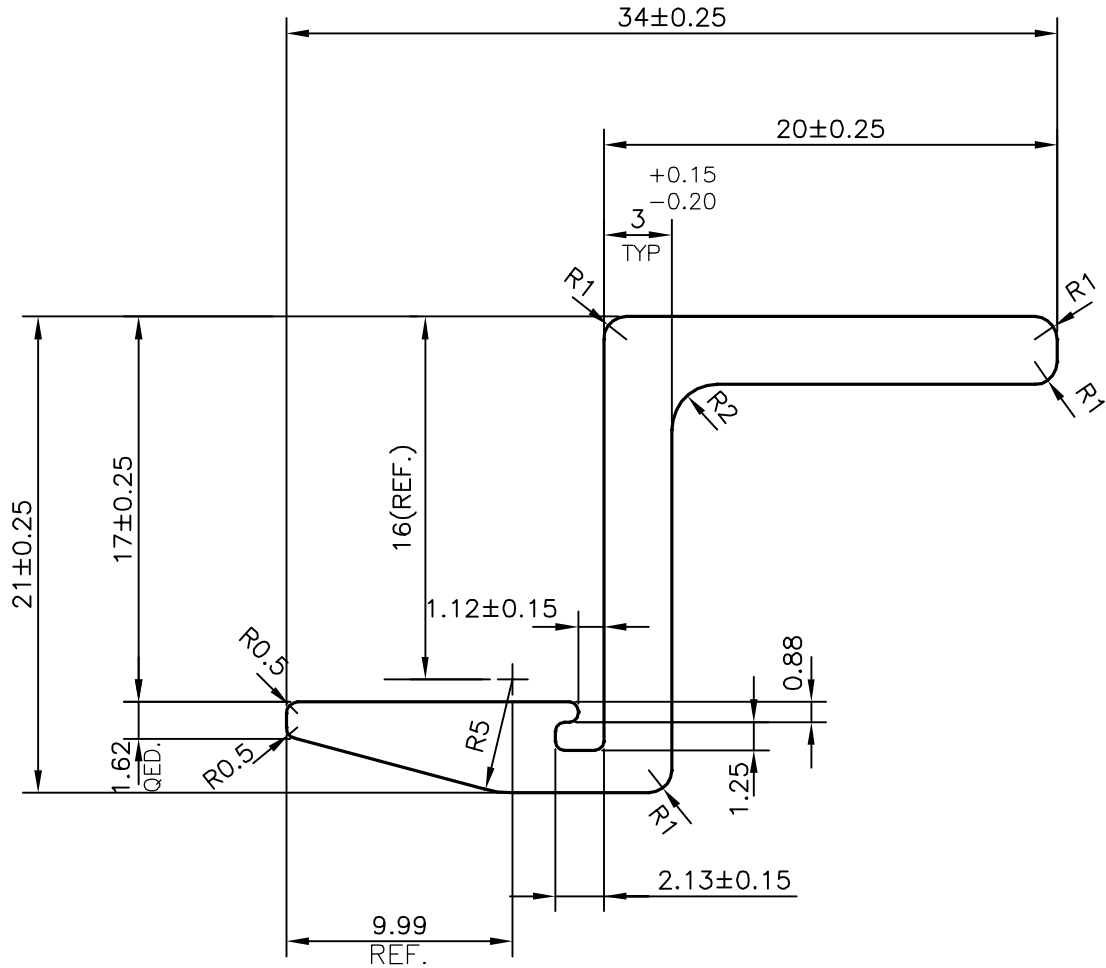
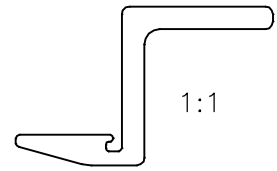

SYMBOL OF QUALITY
AN ISO 9001 COMPANY

JINDAL ALUMINIUM LTD.
BANGALORE-560073 (INDIA)

	NAME	DATE
DRAWN	J.P.KAUSHIK	31-07-2015
CHECKED		
APPROVED	S.S.GARG	05-08-2015

1. ALL DIMENSIONS ARE IN mm.
2. ROUND OFF ALL SHARP CORNERS WITH 0.40 mm.
3. TOLERANCES WILL BE AS PER IS:3965-1981 , UNLESS OTHERWISE SPECIFIED

SCALE	3:1
AREA mm ²	154.637
PERIMETER mm.	110.343
WEIGHT kg/m	0.418

PARTY'S NAME	MARUTI RUB PLAST PVT. LTD., NOIDA	DRAWING No.	P-14927-1	SECTION No.	-
PARTY'S DRAWING No.	30-02727-01		S4559		S4559
ALLOY & TEMPER	6063 T6		28218		28218
DESCRIPTION	MISC. SECTION				