

P-13497-3

S4113

28221

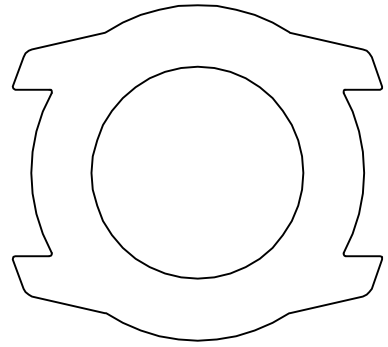

SCALE :- 1:1

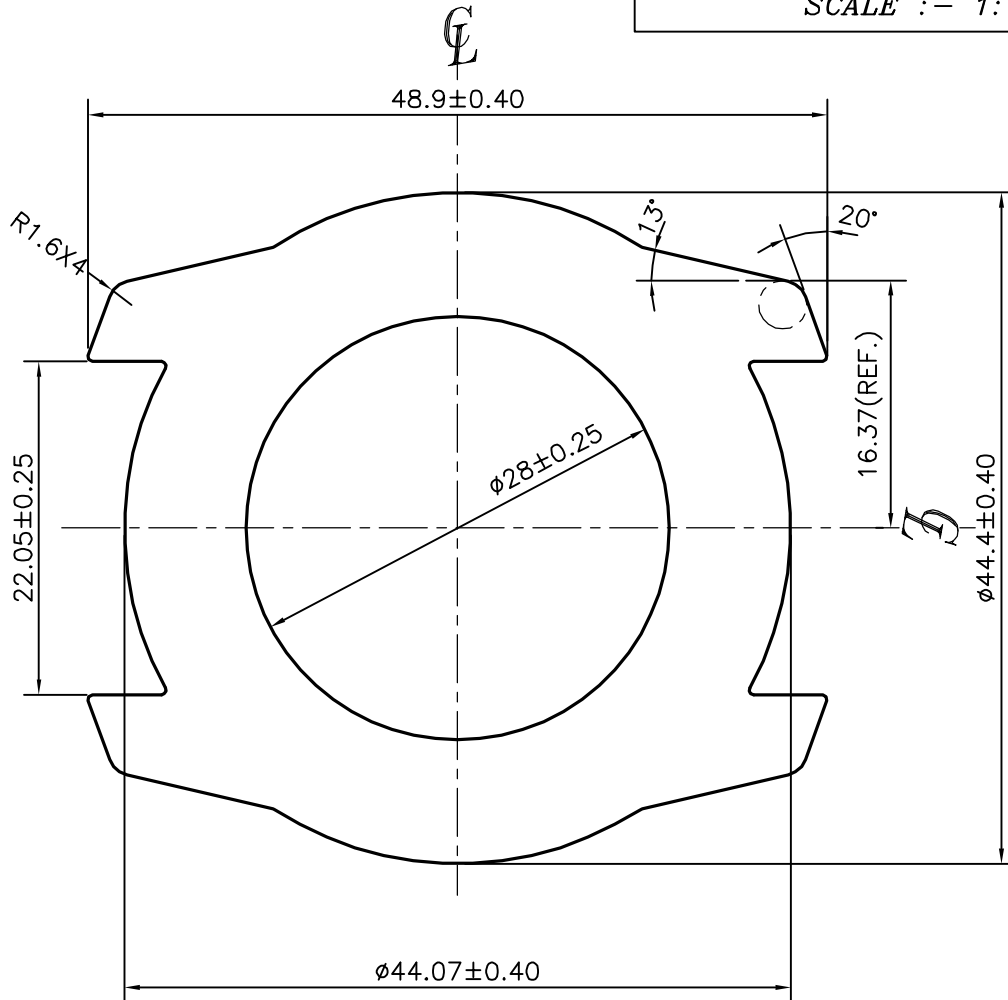

1. STRAIGHTNESS=1.5mm/M
2. TWIST=1.5mm/M
3. OVALITY=±0.50mm



SYMBOL OF QUALITY
AN ISO 9001 COMPANY

JINDAL ALUMINIUM LTD.
BANGALORE-560073 (INDIA)

	NAME	DATE
DRAWN	J.P.KAUSHIK	08-05-2014
CHECKED		
APPROVED	S.S.GARG	19-05-2014
SCALE		2:1
AREA mm ²		1086.439
PERIMETER mm.		181.441
WEIGHT kg/m		2.933
DRAWING No.	SECTION No.	
P-13497-3	-	
S4113	S4113	
28221	28221	

1. ALL DIMENSIONS ARE IN mm.
2. ROUND OFF ALL SHARP CORNERS WITH 0.30 mm.
3. TOLERANCES WILL BE AS PER BS:EN-12020-2, UNLESS OTHERWISE SPECIFIED

PARTY'S NAME	TITAN INDUSTRIES LTD., HOSUR
PARTY'S DRAWING No.	TS-25-109-b
ALLOY & TEMPER	6063 T6
DESCRIPTION	WATCH CASE SECTION