

P-13377-1

X1733

28232

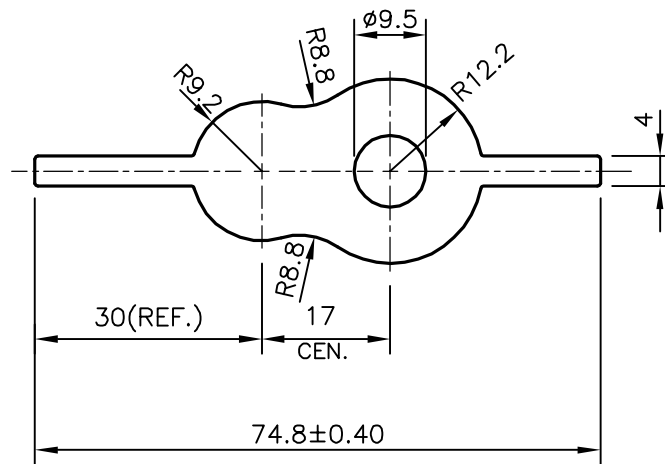

1. TWIST & BEND = 1.7mm/M
2. ANGULARITY = ±2°



SYMBOL OF QUALITY
AN ISO 9001 COMPANY

JINDAL ALUMINIUM LTD.
BANGALORE-560073 (INDIA)

	NAME	DATE
DRAWN	J.P.KAUSHIK	27-01-2014
CHECKED		
APPROVED	S.S.GARG	10-02-2014
SCALE		1:1
AREA mm ²		780.827
PERIMETER mm.		175.306
WEIGHT kg/m		2.108
DRAWING No.	SECTION No.	
P-13377-1	-	
X1733	X1733	
28232	28232	

1. ALL DIMENSIONS ARE IN mm.
2. ROUND OFF ALL SHARP CORNERS WITH 0.40 mm.
3. TOLERANCES WILL BE AS PER BS:EN-755-9, UNLESS OTHERWISE SPECIFIED

PARTY'S NAME	YOONWOO AUTOMOTIVE INDIA PVT. LTD., PUNE
PARTY'S DRAWING No.	AS PER DRAWING
ALLOY & TEMPER	6060 T66
DESCRIPTION	INLET CONNECTING FLANGE