

P-13379

X1735

28234

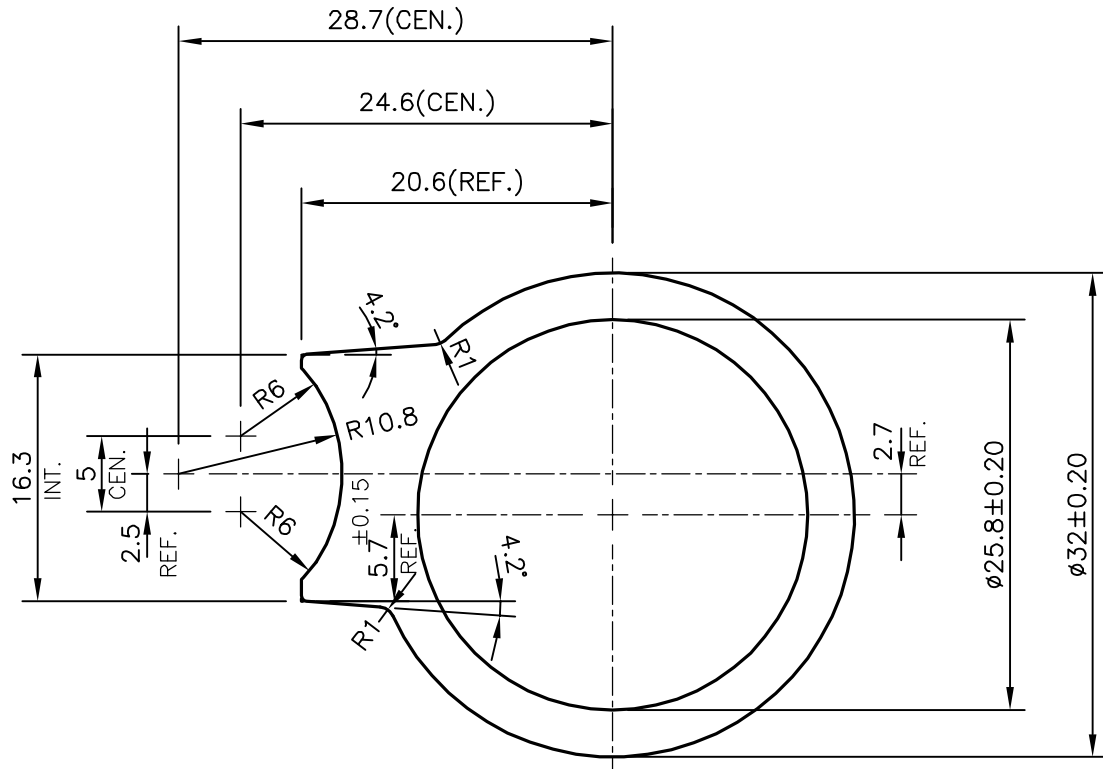
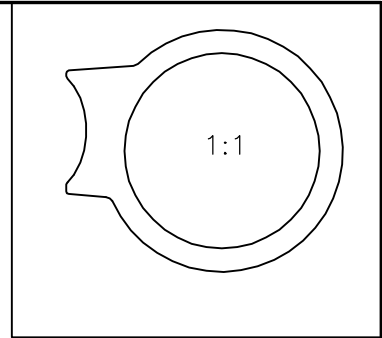

- 1. TWIST & BEND = 1.7mm/M
- 2. ANGULARITY = ±2°



SYMBOL OF QUALITY
AN ISO 9001 COMPANY

JINDAL ALUMINIUM LTD.
BANGALORE-560073 (INDIA)

	NAME	DATE
DRAWN	J.P.KAUSHIK	25-01-2014
CHECKED		
APPROVED	S.S.GARG	10-02-2014
SCALE		2:1
AREA mm ²		349.634
PERIMETER mm.		114.062
WEIGHT kg/m		0.944
DRAWING No.	SECTION No.	
P-13379	-	
X1735	X1735	
28234	28234	

- 1. ALL DIMENSIONS ARE IN mm.
- 2. ROUND OFF ALL SHARP CORNERS WITH 0.40 mm.
- 3. TOLERANCES WILL BE AS PER BS:EN-755-9, UNLESS OTHERWISE SPECIFIED

PARTY'S NAME	YOONWOO AUTOMOTIVE INDIA PVT. LTD., PUNE
PARTY'S DRAWING No.	AS PER AUTO Cad DRAWING
ALLOY & TEMPER	3103 F
DESCRIPTION	KOMO PROFILE LOWER