

P-13884

S4216

28272

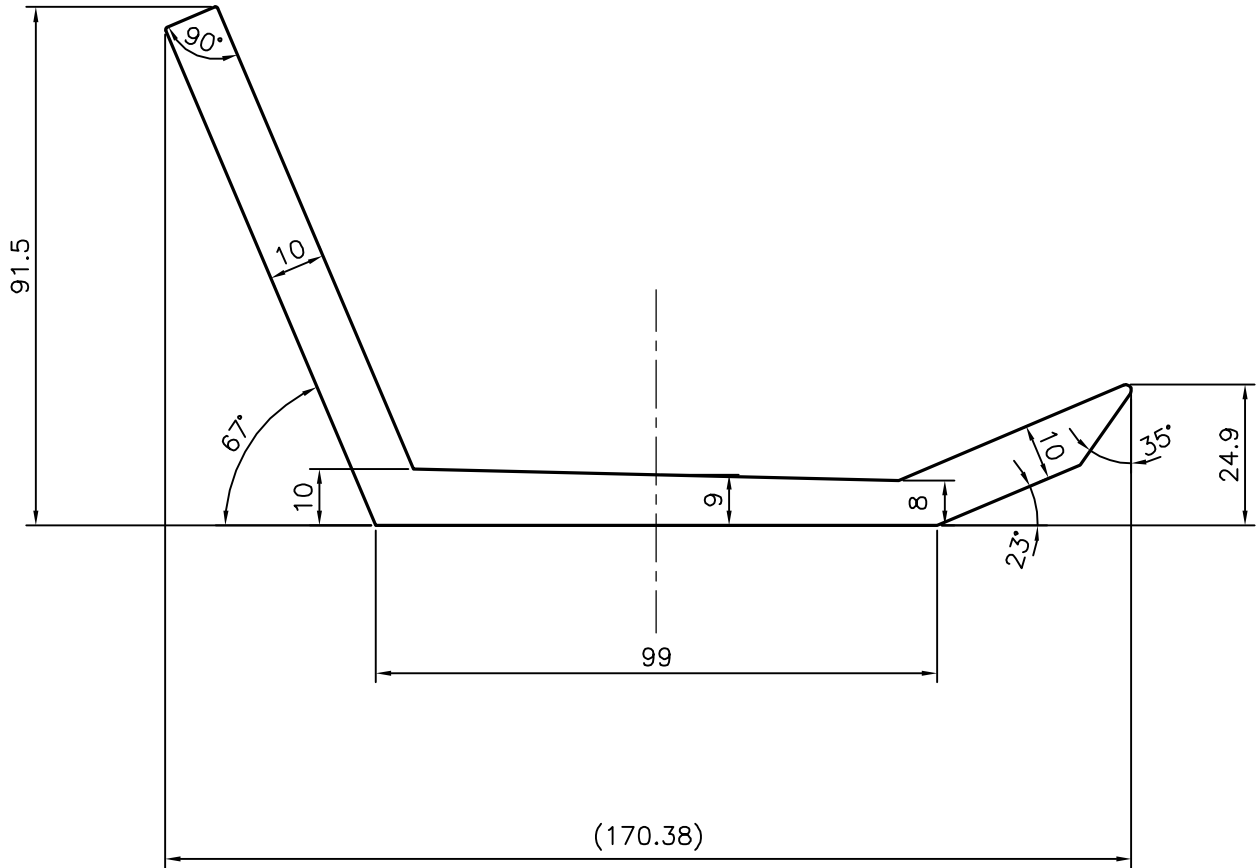

SYMBOL OF QUALITY  
AN ISO 9001 COMPANY

**JINDAL ALUMINIUM LTD.**  
BANGALORE-560073 (INDIA)

	NAME	DATE
DRAWN	J.P.KAUSHIK	16-08-2014
CHECKED		
APPROVED	S.S.GARG	25-08-2014
SCALE		0.75:1
AREA mm <sup>2</sup>		2118.347
PERIMETER mm.		466.739
WEIGHT kg/m		5.720
DRAWING No.	SECTION No.	
P-13884	-	
S4216	S4216	
28272	28272	

1. ALL DIMENSIONS ARE IN mm.
2. ROUND OFF ALL SHARP CORNERS WITH 0.40 mm.
3. TOLERANCES WILL BE AS PER IS:3965-1981, UNLESS OTHERWISE SPECIFIED

PARTY'S NAME	VIGNESH AUTOMATION, CHENNAI
PARTY'S DRAWING No.	AS PER SAMPLE
ALLOY & TEMPER	19501 'M'
DESCRIPTION	MISC. SECTION