

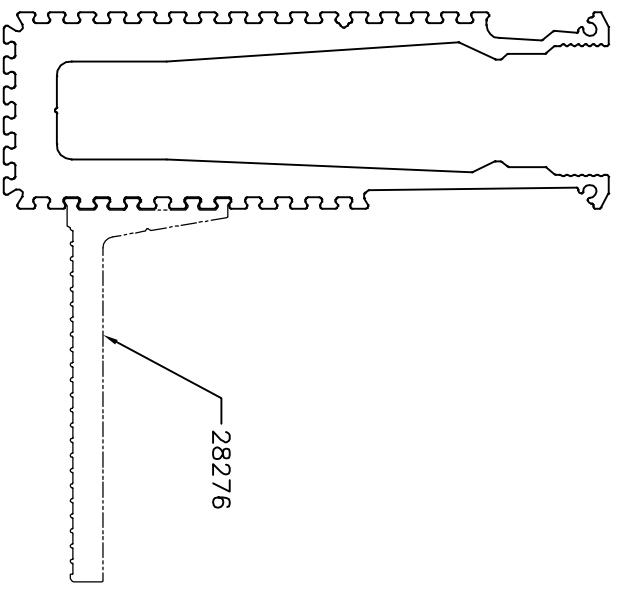

P-14005
S4253
28275

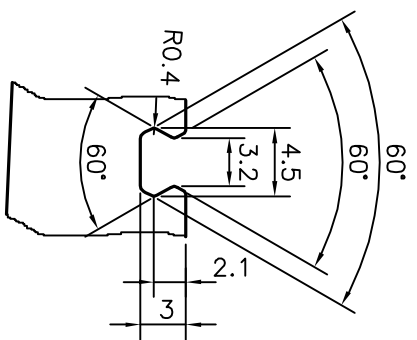
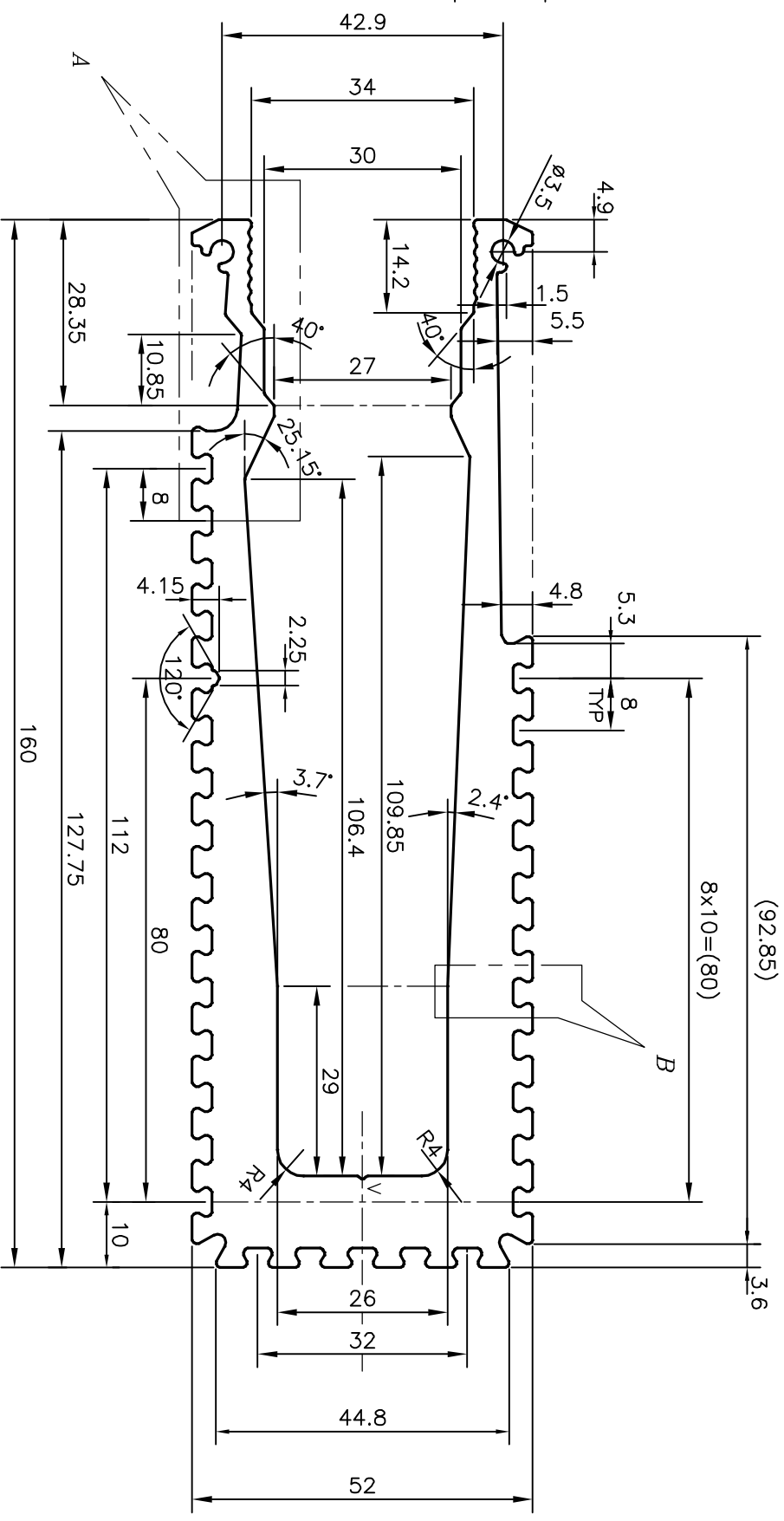
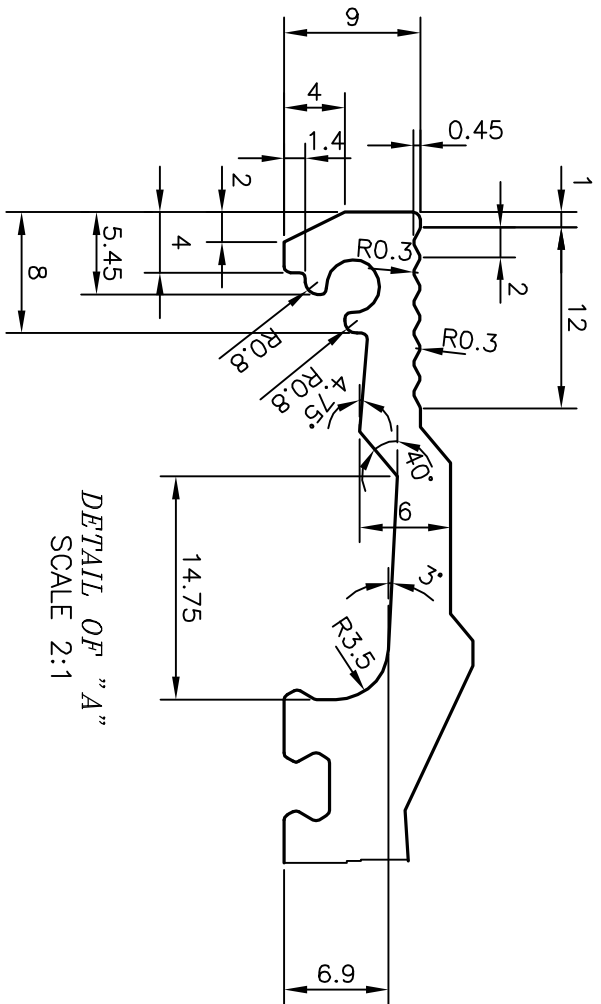

DETAIL OF "B"
SCALE 2:1

V = V GROOVE 0.5x90°

 SYMBOL OF QUALITY AN ISO 9001 COMPANY JINDAL ALUMINIUM LTD. BANGALORE-560073 (INDIA)		NAME	DATE
		DRAWN	J.P.KAUSHIK
1. ALL DIMENSIONS ARE IN mm. 2. ROUND OFF ALL SHARP CORNERS WITH 0.40 mm. 3. TOLERANCES WILL BE AS PER IS:3965-1981 UNLESS OTHERWISE SPECIFIED		CHECKED	
		APPROVED	S.S.GARG
PARTY'S NAME		SCALE	1:1
PARTY'S DRAWING No.		AREA mm ²	3089.097
ALLOY & TEMPER		PERIMETER mm.	941.216
DESCRIPTION		WEIGHT kg/m	8.341
		DRAWING No.	SECTION No.
		P-14005	-
		S4253	S4253
		28275	28275