

P-14283

S4340

28287

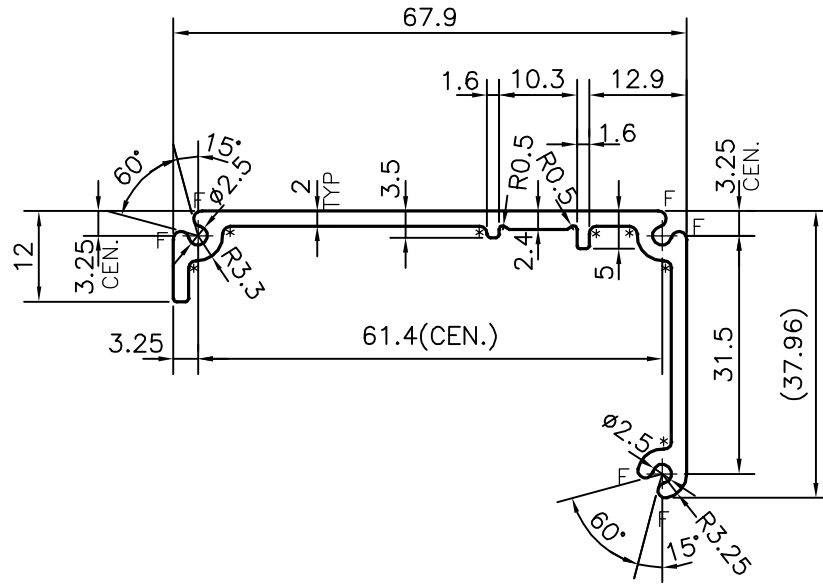

* = 1.0 RADIUS (7 PLACES)
 F = FULL RADIUS (6 PLACES)



SYMBOL OF QUALITY
 AN ISO 9001 COMPANY

JINDAL ALUMINIUM LTD.
 BANGALORE-560073 (INDIA)

	NAME	DATE
DRAWN	J.P.KAUSHIK	25-12-2014
CHECKED		
APPROVED	S.S.GARG	07-01-2015

1. ALL DIMENSIONS ARE IN mm.
2. ROUND OFF ALL SHARP CORNERS WITH 0.40 mm.
3. TOLERANCES WILL BE AS PER IS:3965-1981 , UNLESS OTHERWISE SPECIFIED

SCALE	1:1
AREA mm ²	262.472
PERIMETER mm.	252.155
WEIGHT kg/m	0.709

PARTY'S NAME PLENUM TECH PVT. LTD., NAGPUR

DRAWING No. SECTION No.

PARTY'S DRAWING No. CHANNEL-2014-V01

P-14283 -

ALLOY & TEMPER 6063 T6

S4340 S4340
 28287 28287

DESCRIPTION MISC. SECTION