

P-17047

28298

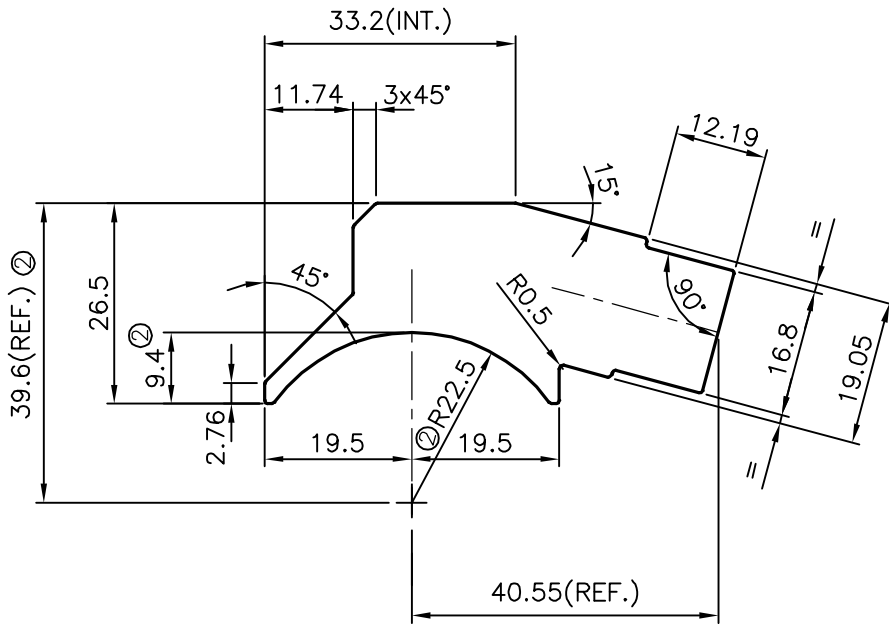

ISSUE-2

DIMENSION CHANGED FROM 31.5 TO 39.6, FROM 12 TO 9.4 & RADIUS CHANGED FROM 17 TO 22.50 mm

WEIGHT ALSO CHANGED FROM 2.473 TO 2.596 kg/m



SYMBOL OF QUALITY
AN ISO 9001 COMPANY

JINDAL ALUMINIUM LTD.
BANGALORE-560073 (INDIA)

	NAME	DATE
DRAWN	J.P.KAUSHIK	23-09-2017
CHECKED		
APPROVED	B.NATARAJA	07-10-2017
SCALE		1:1
AREA mm ²		961.399
PERIMETER mm.		168.171
WEIGHT kg/m		2.596
DRAWING No.	SECTION No.	
P-17047	-	
28298	28298(ISSUE-2)	

1. ALL DIMENSIONS ARE IN mm.
2. ROUND OFF ALL SHARP CORNERS WITH 0.40 mm.
3. TOLERANCES WILL BE AS PER ANSI:H35.2-2009 UNLESS OTHERWISE SPECIFIED

PARTY'S NAME	NINGBO WE-CAN IMPORT-EXPORT CO. LTD., CHINA
PARTY'S DRAWING No.	PARTS No:-826926
ALLOY & TEMPER	6063 T6
DESCRIPTION	MISC. SECTION