

P-12575-1

S4258

28306

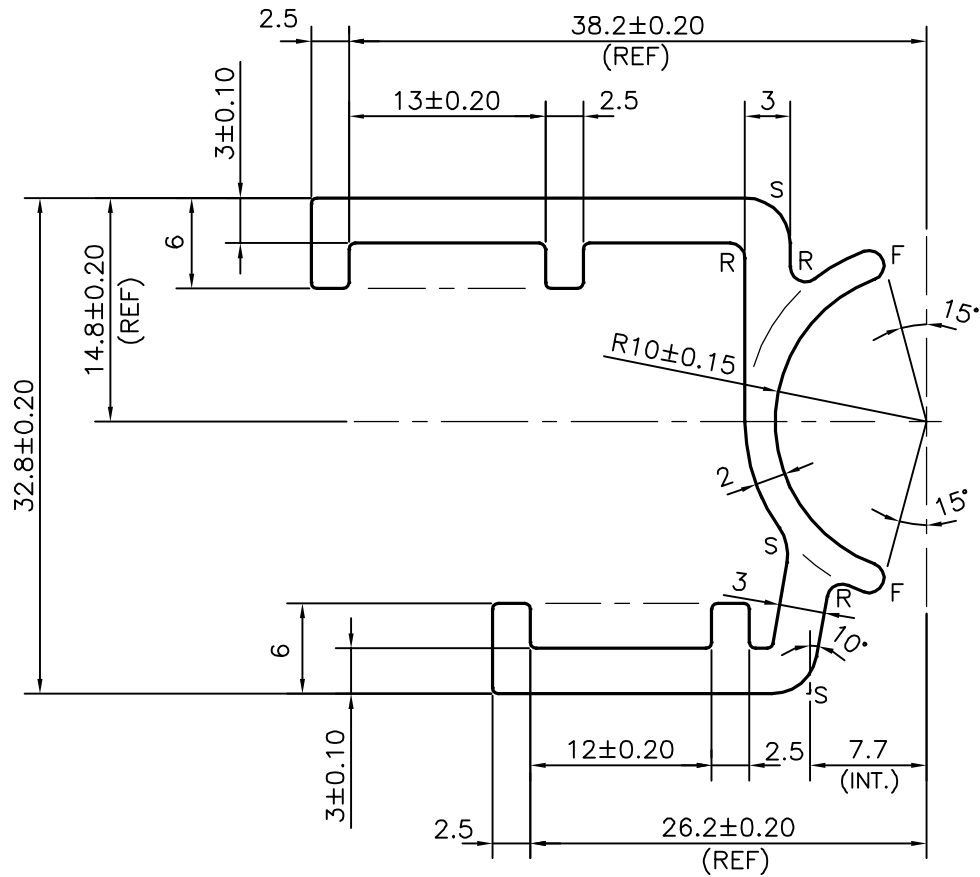
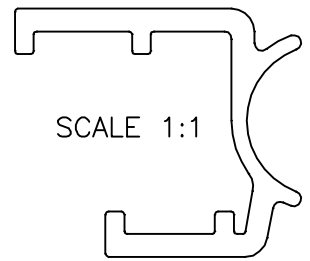

F = FULL RADIUS (2 PLACES)
 R = 1 mm RADIUS (3 PLACES)
 S = 3 mm RADIUS (3 PLACES)



SYMBOL OF QUALITY
 AN ISO 9001 COMPANY

JINDAL ALUMINIUM LTD.
 BANGALORE-560073 (INDIA)

	NAME	DATE
DRAWN	J.P.KAUSHIK	08-08-2014
CHECKED		
APPROVED	S.S.GARG	10-10-2014
SCALE	2:1	
AREA mm ²	281.069	
PERIMETER mm.	202.561	
WEIGHT kg/m	0.759	
DRAWING No.	SECTION No.	
P-12575-1	-	
S4258	S4258	
28306	28306	

1. ALL DIMENSIONS ARE IN mm.
2. ROUND OFF ALL SHARP CORNERS WITH 0.40 mm.
3. TOLERANCES WILL BE AS PER BS:EN-12020-2 , UNLESS OTHERWISE SPECIFIED

PARTY'S NAME	WONJIN AUTOPARTS INDIA PVT. LTD., MARAIMALAI NAGAR
PARTY'S DRAWING No.	PL F841QQDAA01 000
ALLOY & TEMPER	6005 T5
DESCRIPTION	BRKT-MTG SECTION