

P-12578-1

S4260

28308

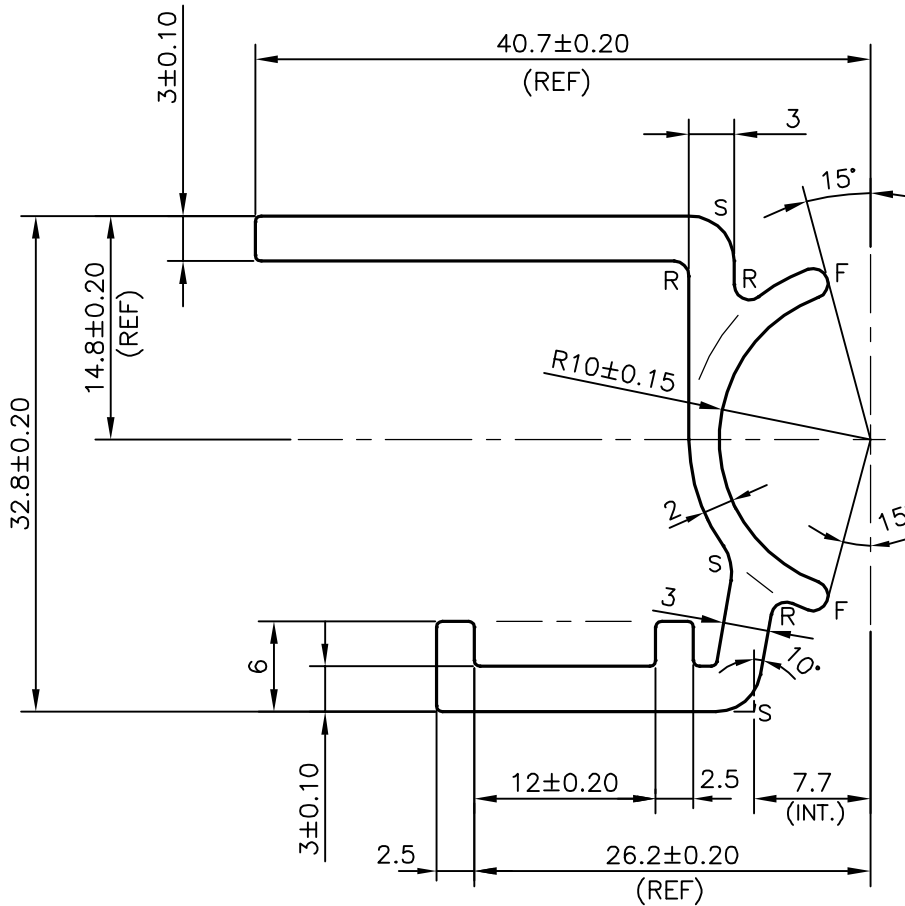
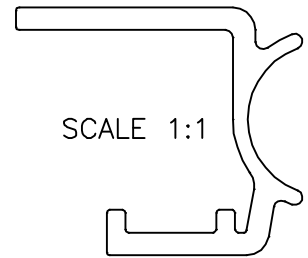

F = FULL RADIUS (2 PLACES)
 R = 1 mm RADIUS (3 PLACES)
 S = 3 mm RADIUS (3 PLACES)



SYMBOL OF QUALITY
 AN ISO 9001 COMPANY

JINDAL ALUMINIUM LTD.
 BANGALORE-560073 (INDIA)

	NAME	DATE
DRAWN	J.P.KAUSHIK	08-08-2014
CHECKED		
APPROVED	S.S.GARG	10-10-2014
SCALE		2:1
AREA mm ²		266.069
PERIMETER mm.		191.591
WEIGHT kg/m		0.718
DRAWING No.	SECTION No.	
P-12578-1	-	
S4260	S4260	
28308	28308	

1. ALL DIMENSIONS ARE IN mm.
2. ROUND OFF ALL SHARP CORNERS WITH 0.40 mm.
3. TOLERANCES WILL BE AS PER BS:EN-12020-2 , UNLESS OTHERWISE SPECIFIED

PARTY'S NAME	WONJIN AUTOPARTS INDIA PVT. LTD., MARAIMALAI NAGAR
PARTY'S DRAWING No.	PL F842QQDAA01 000
ALLOY & TEMPER	6005 T5
DESCRIPTION	BRKT-(A) COND MTG SECTION