

P-12579-2

S4261

28309

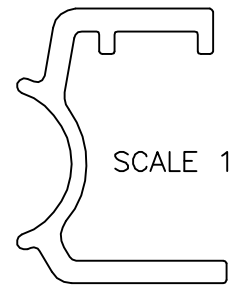

SCALE 1:1

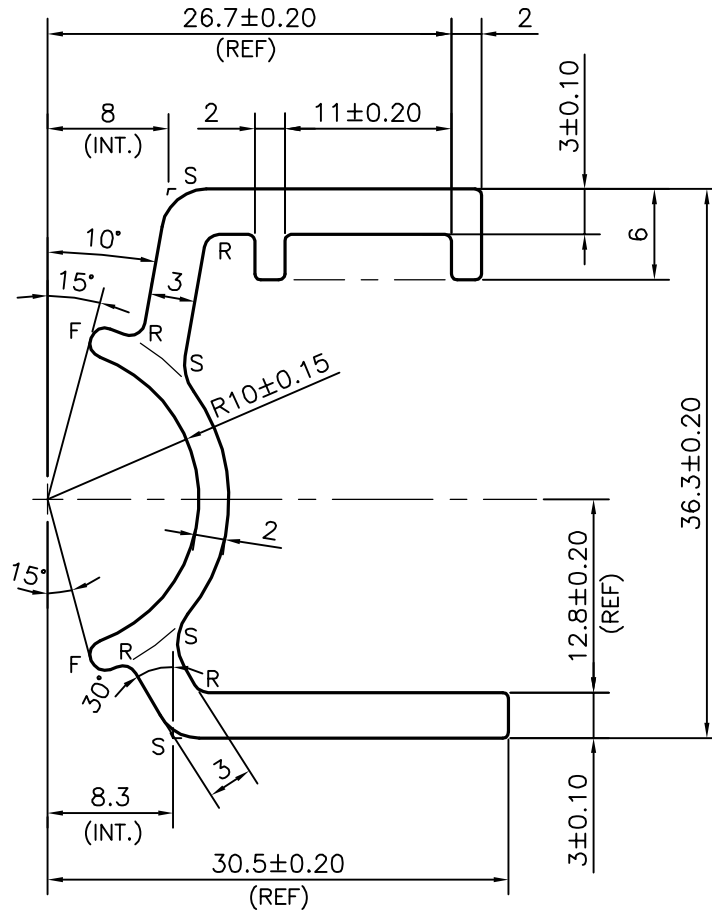

F = FULL RADIUS (2 PLACES)  
 R = 1 mm RADIUS (4 PLACES)  
 S = 3 mm RADIUS (4 PLACES)



SYMBOL OF QUALITY  
 AN ISO 9001 COMPANY

**JINDAL ALUMINIUM LTD.**  
 BANGALORE-560073 (INDIA)

	NAME	DATE
DRAWN	J.P.KAUSHIK	08-08-2014
CHECKED		
APPROVED	S.S.GARG	10-10-2014
SCALE	2:1	
AREA mm <sup>2</sup>	235.773	
PERIMETER mm.	177.764	
WEIGHT kg/m	0.637	
DRAWING No.	SECTION No.	
P-12579-2	-	
S4261	S4261	
28309	28309	

1. ALL DIMENSIONS ARE IN mm.
2. ROUND OFF ALL SHARP CORNERS WITH 0.40 mm.
3. TOLERANCES WILL BE AS PER BS:EN-12020-2, UNLESS OTHERWISE SPECIFIED

PARTY'S NAME	WONJIN AUTOPARTS INDIA PVT. LTD., MARAIMALAI NAGAR
PARTY'S DRAWING No.	PL F842QQDAB01 000
ALLOY & TEMPER	6005 T5
DESCRIPTION	BRKT- (A) COND MTG SECTION