

P-17569

S5549

28348

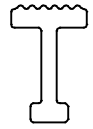

1:1

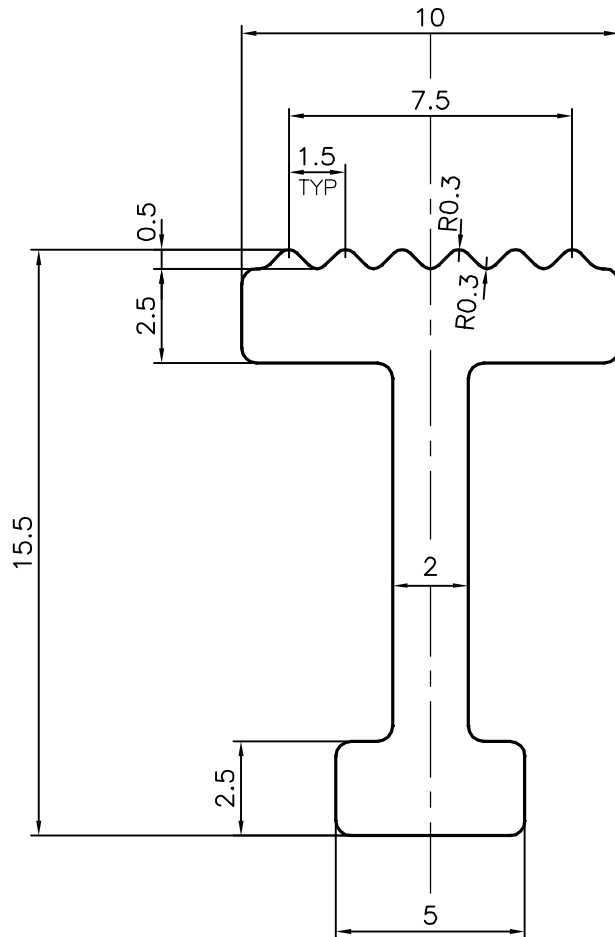

## TOLERANCES ON OVERALL WIDTHS &amp; WIDTHS ACROSS FLATS OF BARS, &amp; REGULAR SECTIONS

UPTO 6.40mm - $\pm 0.20$	UPTO 32.0mm - $\pm 0.38$	UPTO 120.0mm - $\pm 0.85$	1. STRAIGHTNESS=1.0mm/M 2. TWIST=1.0mm/M 3. ANGULARITY= $\pm 1^\circ$ 4. FLATNESS =0.007xWIDTH
UPTO 10.0mm - $\pm 0.23$	UPTO 50.0mm - $\pm 0.46$	UPTO 160.0mm - $\pm 1.02$	
UPTO 12.0mm - $\pm 0.25$	UPTO 60.0mm - $\pm 0.53$	UPTO 200.0mm - $\pm 1.14$	
UPTO 16.0mm - $\pm 0.28$	UPTO 80.0mm - $\pm 0.69$	UPTO 250.0mm - $\pm 1.40$	
UPTO 25.0mm - $\pm 0.30$	UPTO 100.0mm - $\pm 0.75$	UPTO 300.0mm - $\pm 1.65$	



SYMBOL OF QUALITY  
AN ISO 9001 COMPANY

**JINDAL ALUMINIUM LTD.**  
BANGALORE-560073 (INDIA)

	NAME	DATE
DRAWN	J.P.KAUSHIK	18-10-2017
CHECKED		
APPROVED	J.N.RAI	30-10-2017

1. ALL DIMENSIONS ARE IN mm.
2. ROUND OFF ALL SHARP CORNERS WITH 0.40 mm.
3. TOLERANCES WILL BE AS PER IS:3965-1981 , UNLESS OTHERWISE SPECIFIED

SCALE	5:1
AREA mm <sup>2</sup>	59.612
PERIMETER mm.	56.105
WEIGHT kg/m	0.161

PARTY'S NAME	WEST COAST ENGINEERING WORKS PVT. LTD., MUMBAI
PARTY'S DRAWING No.	DRG-513/5 R-1
ALLOY & TEMPER	6063 T6
DESCRIPTION	MISC. SECTION

DRAWING No.	SECTION No.
P-17569	-
S5549	S5549
28348	28348