

P-15342

S4751

28350



1:1

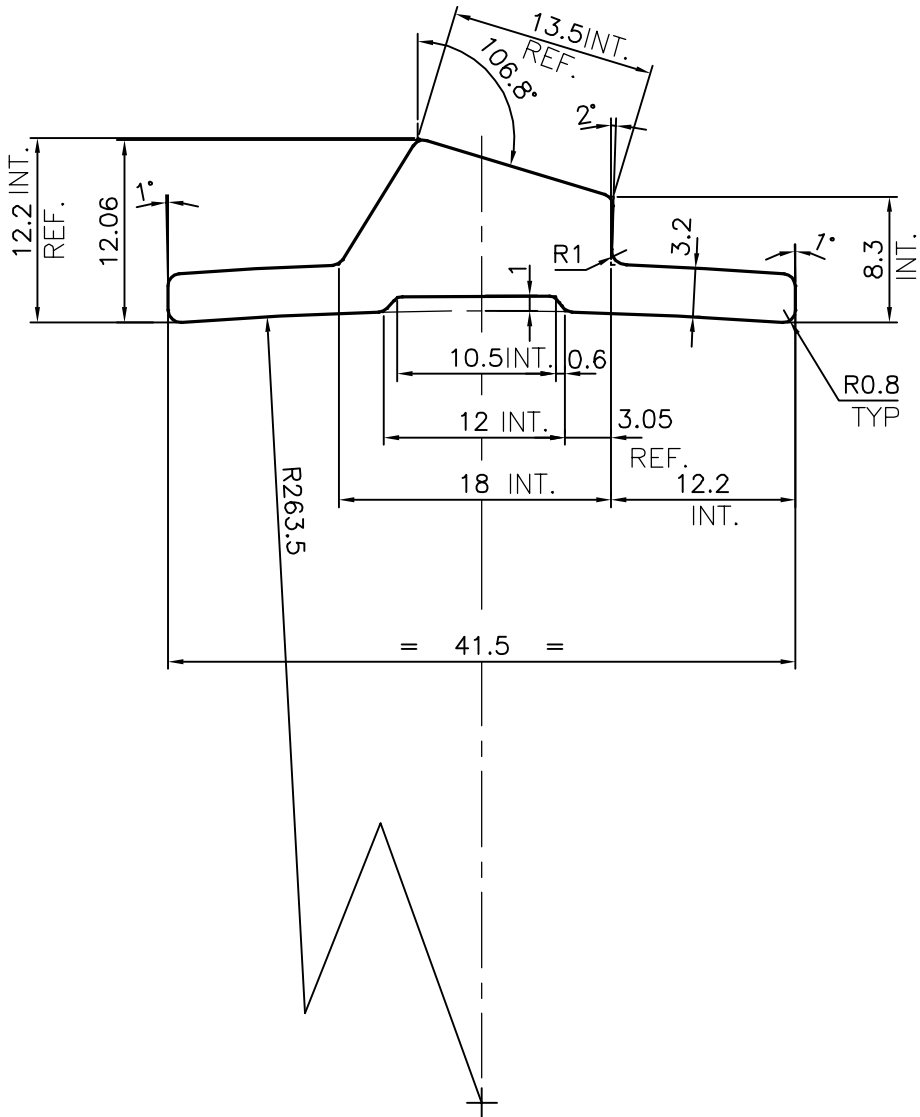

SYMBOL OF QUALITY
AN ISO 9001 COMPANY

JINDAL ALUMINIUM LTD.
BANGALORE-560073 (INDIA)

	NAME	DATE
DRAWN	J.P.KAUSHIK	23-11-2015
CHECKED		
APPROVED	S.S.GARG	05-12-2015
SCALE		2:1
AREA mm ²		224.274
PERIMETER mm.		97.949
WEIGHT kg/m		0.606
DRAWING No.	SECTION No.	
P-15342	-	
S4751	S4751	
28350	28350	

1. ALL DIMENSIONS ARE IN mm.
2. ROUND OFF ALL SHARP CORNERS WITH 0.40 mm.
3. TOLERANCES WILL BE AS PER IS:3965-1981 UNLESS OTHERWISE SPECIFIED

PARTY'S NAME: STOVEKRAFT PVT. LTD., BANGALORE

PARTY'S DRAWING No.: AS PER AutoCAD DRAWING

ALLOY & TEMPER: 6351 T6

DESCRIPTION: B COOKER BRACKET SECTION