

P-17775-1

28360

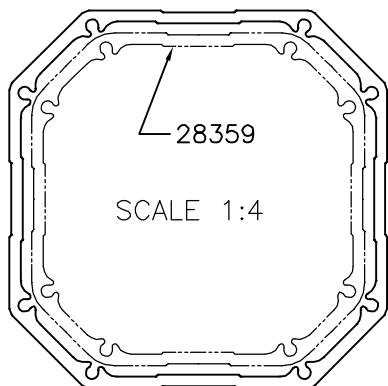
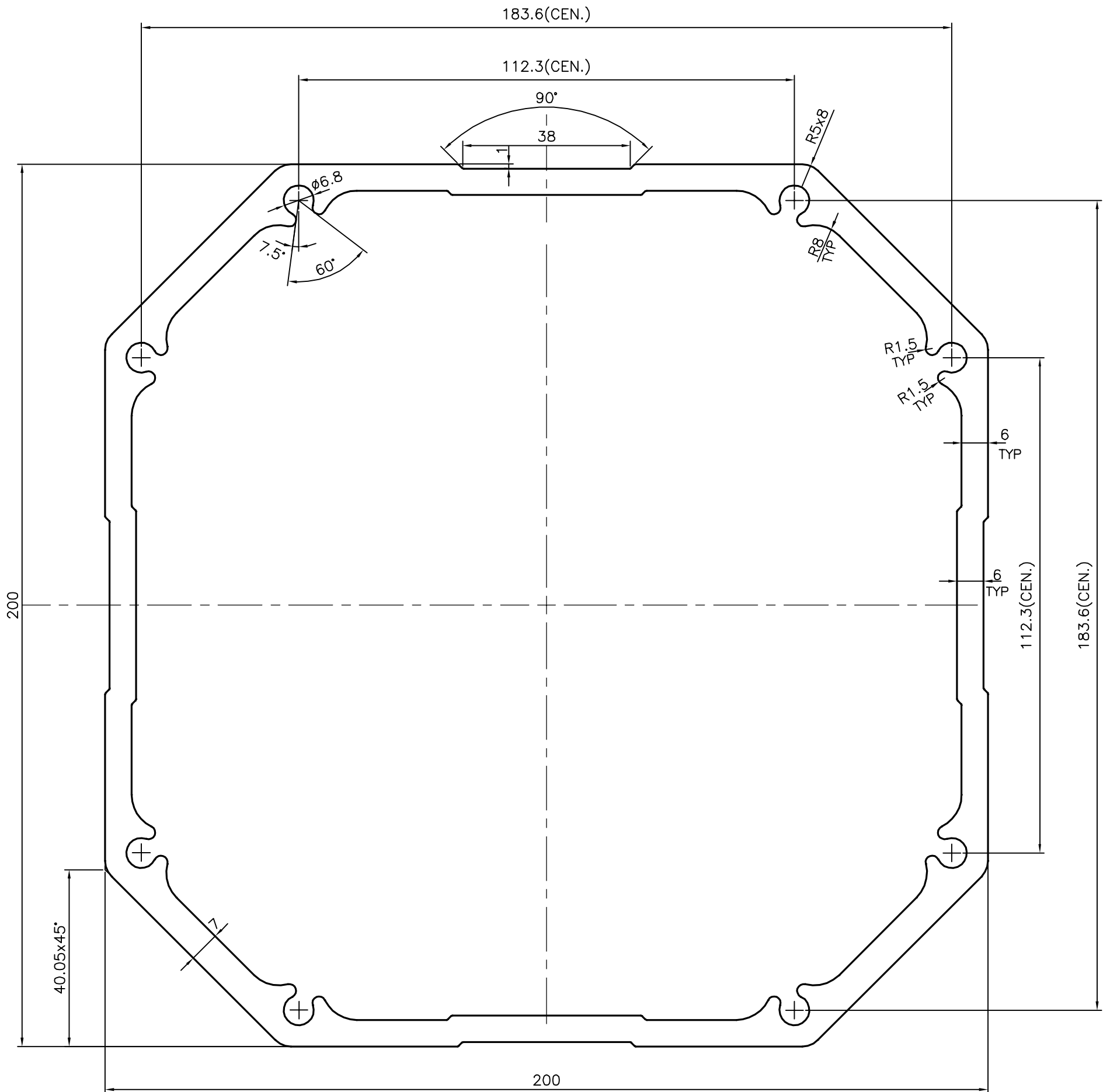

TOLERANCES ON OVERALL DIMENSIONS OF HOLLOW SECTIONS

UPTO 20.0mm - ±0.30	UPTO 80.0mm - ±0.70
UPTO 30.0mm - ±0.38	UPTO 100.0mm - ±0.80
UPTO 40.0mm - ±0.45	UPTO 120.0mm - ±0.90
UPTO 50.0mm - ±0.52	UPTO 140.0mm - ±1.00
UPTO 60.0mm - ±0.60	UPTO 160.0mm - ±1.14

UPTO 80.0mm - ±0.70	UPTO 180.0mm - ±1.27
UPTO 100.0mm - ±0.80	UPTO 200.0mm - ±1.40
UPTO 120.0mm - ±0.90	UPTO 225.0mm - ±1.52

UPTO 180.0mm - ±1.27
UPTO 200.0mm - ±1.40
UPTO 225.0mm - ±1.52

1. STRAIGHTNESS=1.7mm/M
2. TWIST=1.7mm/M
3. ANGULARITY= ±2°
4. FLATNESS =0.006xWIDTH

JINDAL
 SYMBOL OF QUALITY
 AN ISO 9001 COMPANY

JINDAL ALUMINIUM LTD.
 BANGALORE-560073 (INDIA)

1. ALL DIMENSIONS ARE IN mm.
2. ROUND OFF ALL SHARP CORNERS WITH 0.40 mm.
3. TOLERANCES WILL BE AS PER IS:6477-1983 UNLESS OTHERWISE SPECIFIED

PARTY'S NAME	GENERAL CATEGORY, AHMEDABAD MARKET
PARTY'S DRAWING No.	AS PER DRAWING
ALLOY & TEMPER	HE9 WP
DESCRIPTION	SQUARE TUBE-MISC.

	NAME	DATE
DRAWN	J.P.KAUSHIK	01-03-2018
CHECKED		
APPROVED	B.NATARAJA	29-03-2018
SCALE		1:1
AREA mm ²		4610.368
PERIMETER mm.		707.591
WEIGHT kg/m		12.448
DRAWING No.		SECTION No.
P-17775-1		-
28360		28360