

P-15561-1

S4873

28373

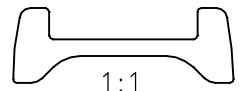

1:1

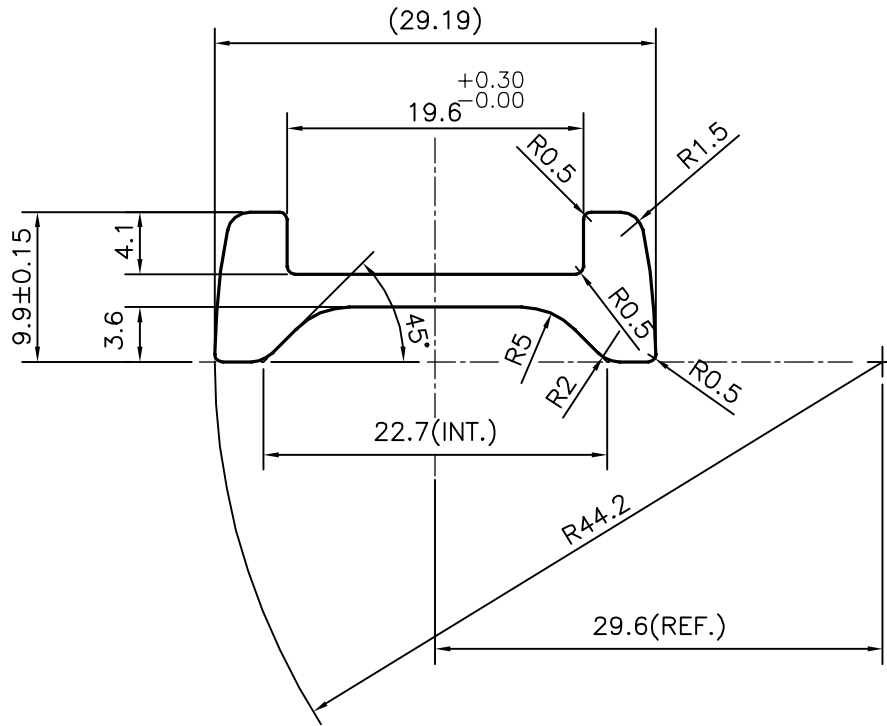

SYMBOL OF QUALITY
AN ISO 9001 COMPANY

JINDAL ALUMINIUM LTD.
BANGALORE-560073 (INDIA)

	NAME	DATE
DRAWN	J.P.KAUSHIK	26-02-2016
CHECKED		
APPROVED	S.S.GARG	01-03-2016
SCALE		2:1
AREA mm ²		132.797
PERIMETER mm.		84.64
WEIGHT kg/m		0.359
DRAWING No.	SECTION No.	
P-15561-1	-	
S4873	S4873	
28373	28373	

1. ALL DIMENSIONS ARE IN mm.
2. ROUND OFF ALL SHARP CORNERS WITH 0.40 mm.
3. TOLERANCES WILL BE AS PER, IS:3965-1981 UNLESS OTHERWISE SPECIFIED

PARTY'S NAME	STOVEKRAFT PVT. LTD., BANGALORE
PARTY'S DRAWING No.	AS PER Auto CAD DRAWING & REQUIREMENT
ALLOY & TEMPER	6351 T6
DESCRIPTION	H BRACKET SECTION