

P-17392

S5491

28381

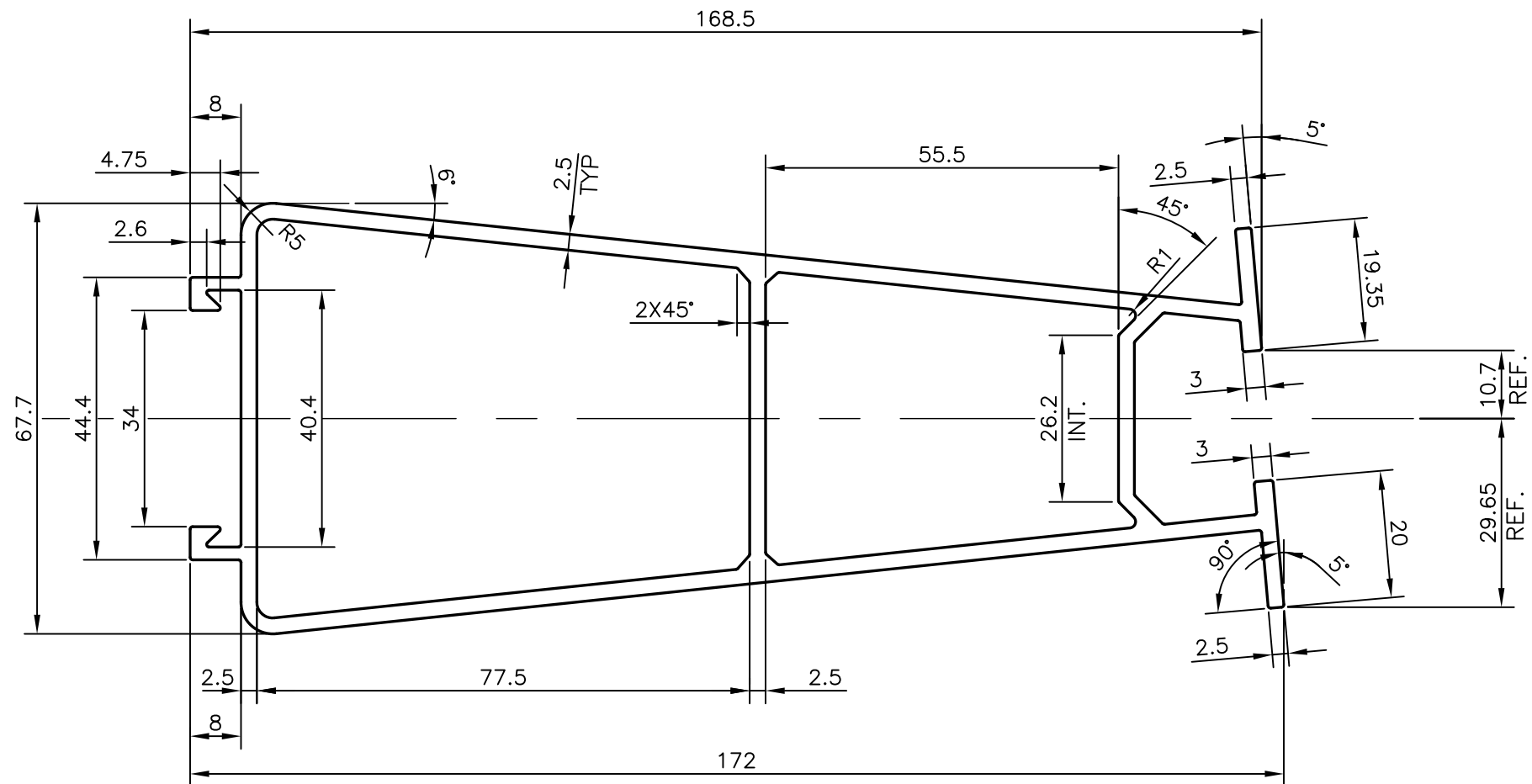

TOLERANCES ON OVERALL DIMENSIONS OF HOLLOW SECTIONS

UPTO 20.0mm - ±0.30	UPTO 80.0mm - ±0.70	UPTO 180.0mm - ±1.27
UPTO 30.0mm - ±0.38	UPTO 100.0mm - ±0.80	UPTO 200.0mm - ±1.40
UPTO 40.0mm - ±0.45	UPTO 120.0mm - ±0.90	UPTO 225.0mm - ±1.52
UPTO 50.0mm - ±0.52	UPTO 140.0mm - ±1.00	
UPTO 60.0mm - ±0.60	UPTO 160.0mm - ±1.14	

1. STRAIGHTNESS=1.7mm/M
2. TWIST=1.7mm/M
3. ANGULARITY= ±2°
4. FLATNESS =0.006xWIDTH

 SYMBOL OF QUALITY AN ISO 9001 COMPANY	JINDAL ALUMINIUM LTD. BANGALORE-560073 (INDIA)	NAME	DATE
		DRAWN	J.P.KAUSHIK
		CHECKED	
		APPROVED	B.NATARAJA
			28-08-2017
1. ALL DIMENSIONS ARE IN mm. 2. ROUND OFF ALL SHARP CORNERS WITH 0.50 mm. 3. TOLERANCES WILL BE AS PER,IS:6477-1983 UNLESS OTHERWISE SPECIFIED		SCALE	1:1
		AREA mm ²	1325.875
		PERIMETER mm.	578.287
		WEIGHT kg/m	3.580
PARTY'S NAME	STROLAR MOUNTING SYSTEMS PVT. LTD., NEW DELHI	DRAWING No.	SECTION No.
PARTY'S DRAWING No.	AS PER AutoCAD DRAWING	P-17392	-
ALLOY & TEMPER	6063 T6	S5491	S5491
DESCRIPTION	MISC. SECTION	28381	28381