

P-17763

S5638

28391

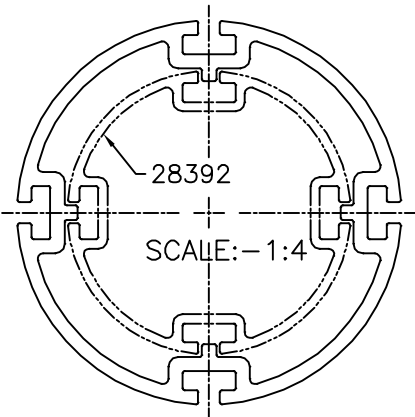
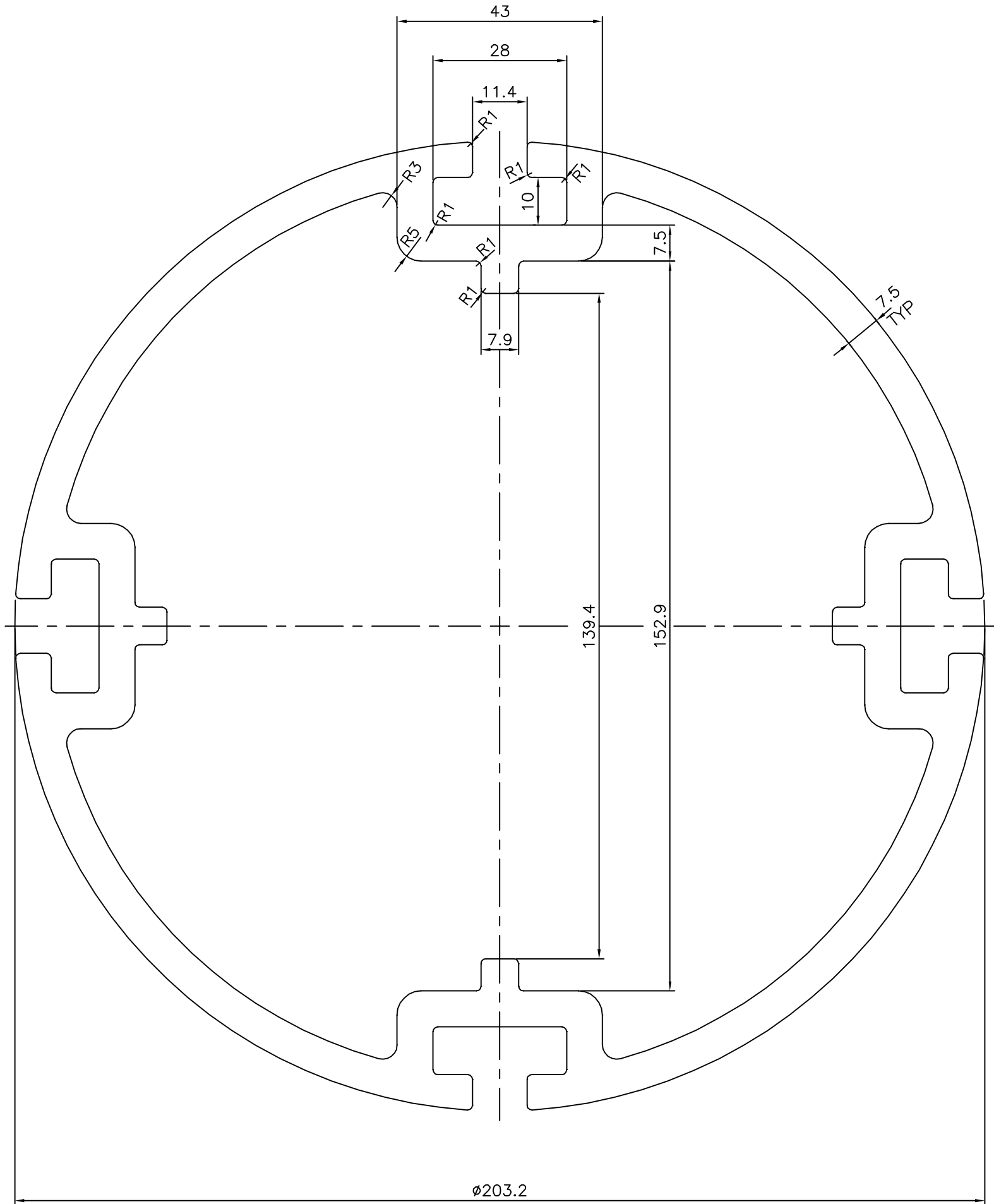

TOLERANCES ON OVERALL DIMENSIONS OF HOLLOW SECTIONS

UPTO 20.0mm - ±0.30	UPTO 80.0mm - ±0.70	UPTO 180.0mm - ±1.27	1. STRAIGHTNESS=1.7mm/M 2. TWIST=1.7mm/M 3. ANGULARITY= ±2° 4. FLATNESS =0.006xWIDTH
UPTO 30.0mm - ±0.38	UPTO 100.0mm - ±0.80	UPTO 200.0mm - ±1.40	
UPTO 40.0mm - ±0.45	UPTO 120.0mm - ±0.90	UPTO 225.0mm - ±1.52	
UPTO 50.0mm - ±0.52	UPTO 140.0mm - ±1.00		
UPTO 60.0mm - ±0.60	UPTO 160.0mm - ±1.14		

 SYMBOL OF QUALITY AN ISO 9001 COMPANY	JINDAL ALUMINIUM LTD. BANGALORE-560073 (INDIA)	NAME	DATE
		DRAWN	J.P.KAUSHIK 05-01-2018
1. ALL DIMENSIONS ARE IN mm. 2. ROUND OFF ALL SHARP CORNERS WITH 0.40 mm. 3. TOLERANCES WILL BE AS PER IS:6477-1983 UNLESS OTHERWISE SPECIFIED		CHECKED	
		APPROVED	B.NATARAJA 11-01-2018
PARTY'S NAME WORKSPACE METAL SOLUTION PVT. LTD., UDAIPUR		SCALE	1:1
		AREA mm ²	6236.199
PARTY'S DRAWING No. AS PER DRAWING		PERIMETER mm.	896.811
		WEIGHT kg/m	16.838
ALLOY & TEMPER 6063 T6		DRAWING No.	SECTION No.
		P-17763	-
DESCRIPTION BEAM SECTION		S5638	S5638
		28391	28391