

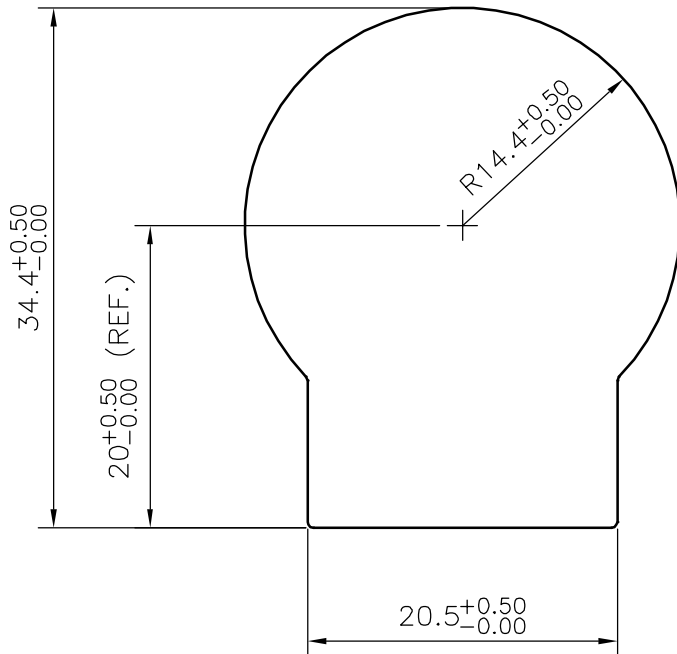

P-16236
S5067
28394

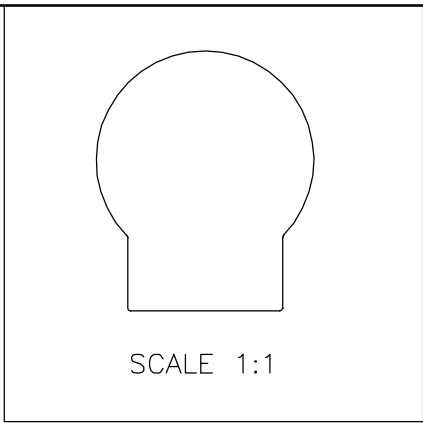

ISSUE-2

TOLERANCE ADDED ON DIMENSIONS $20.5^{+0.50/-0.00}$, $34.4^{+0.50/-0.00}$, $20^{+0.50/-0.00}$ & $R14.4^{+0.50/-0.00}$

 SYMBOL OF QUALITY AN ISO 9001 COMPANY	JINDAL ALUMINIUM LTD. BANGALORE-560073 (INDIA)		NAME	DATE
		DRAWN	KIRAN	24-09-2016
1. ALL DIMENSIONS ARE IN mm. 2. ROUND OFF ALL SHARP CORNERS WITH 0.40 mm. 3. TOLERANCES WILL BE AS PER IS:3965-1981, UNLESS OTHERWISE SPECIFIED		CHECKED		
		APPROVED	S.S. GARG	27-09-2016
PARTY'S NAME VEER-O-METALS PVT. LTD., BANGALORE		SCALE		2:1
		AREA mm ²		793.465
PARTY'S DRAWING No. AS PER DRAWING		PERIMETER mm.		107.561
		WEIGHT kg/m		2.142
ALLOY & TEMPER 6060 'O'		DRAWING No.		P-16236
		SECTION No.		S5067(S5067(ISSUE2))
DESCRIPTION E-CORE END CAP				28394
				28394