

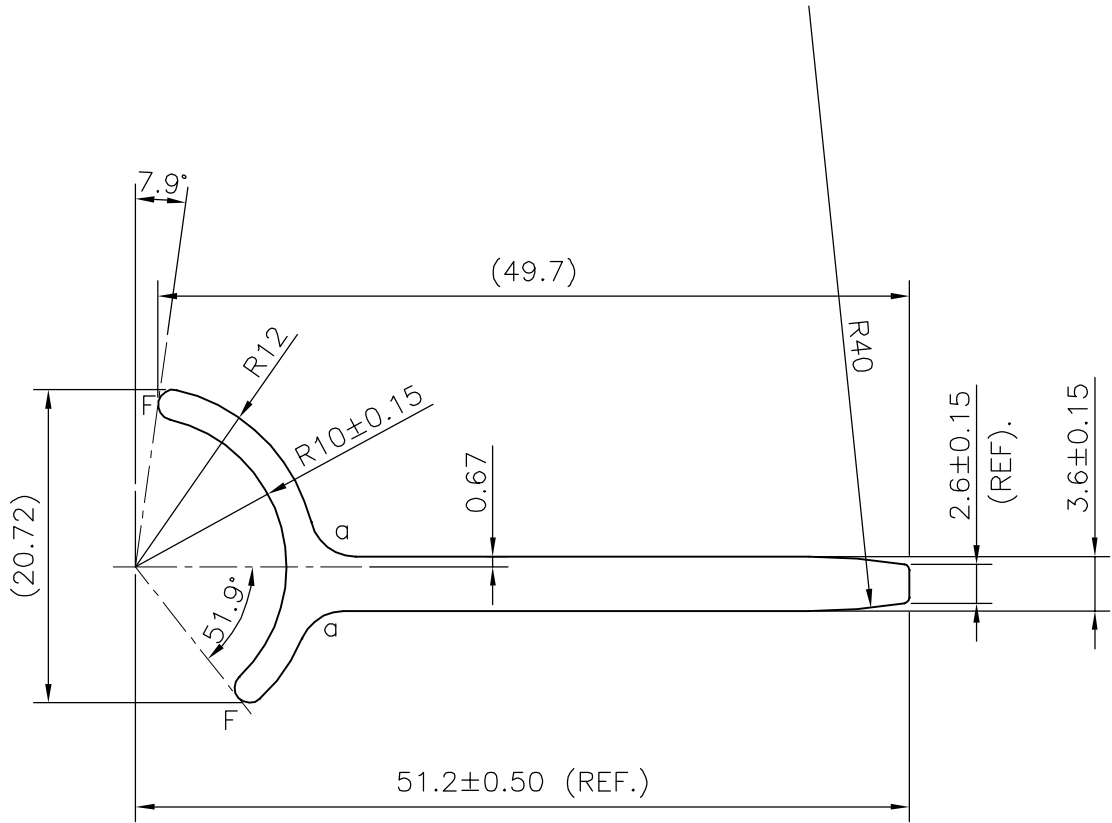

P-16153-1
S5085
28401

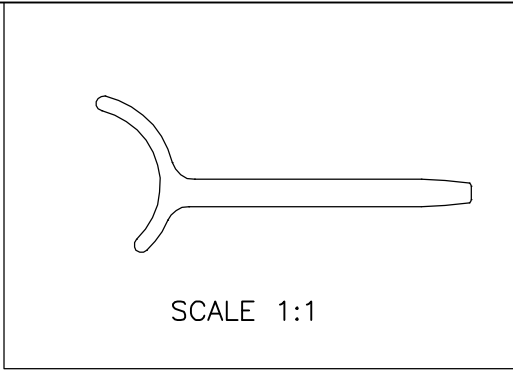

a=RADIUS 3.0 (2 PLACES)
 F=FULL RADIUS (2 PLACES)

 SYMBOL OF QUALITY AN ISO 9001 COMPANY	JINDAL ALUMINIUM LTD. BANGALORE-560073 (INDIA)	NAME	DATE
		DRAWN	KIRAN
1. ALL DIMENSIONS ARE IN mm. 2. ROUND OFF ALL SHARP CORNERS WITH 0.40 mm. 3. TOLERANCES WILL BE AS PER IS:3965-1981, UNLESS OTHERWISE SPECIFIED		CHECKED	
		APPROVED	S.S. GARG
PARTY'S NAME WONJIN AUTOPARTS INDIA PVT.LTD., CHENNAI		SCALE	2:1
		AREA mm ²	191.545
PARTY'S DRAWING No. 00317047-01		PERIMETER mm.	129.738
		WEIGHT kg/m	0.517
ALLOY & TEMPER 6005 T5		DRAWING No.	SECTION No.
		P-16153-1	-
DESCRIPTION BRKT TOC-COMBO COOLER		S5085	S5085
		28401	28401