

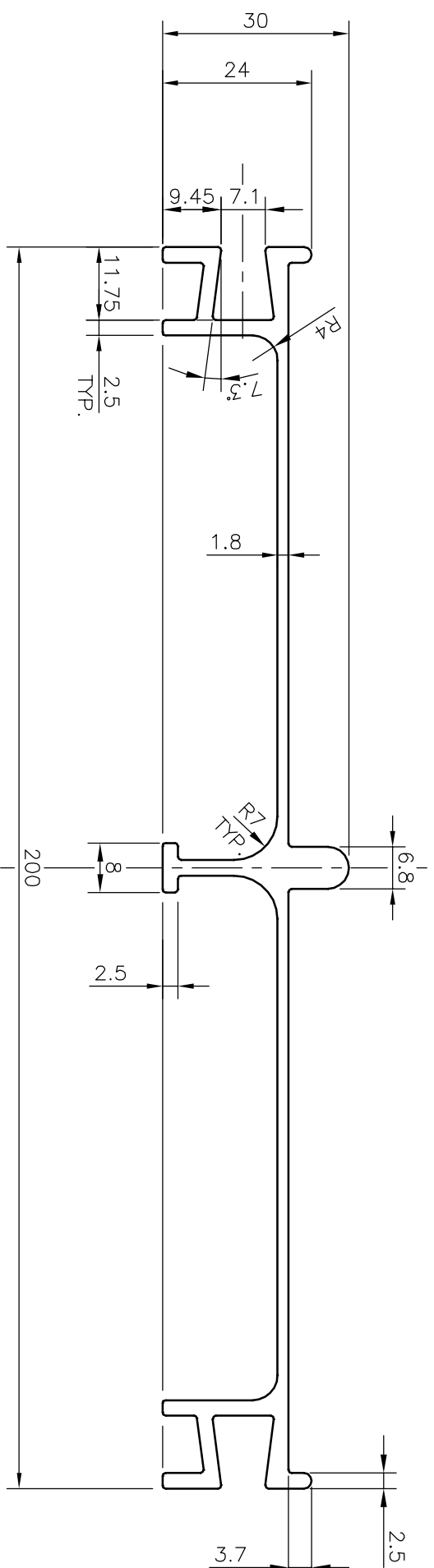

P-16388-1

S5094

28403



COMMON RADIUS WILL BE 0.50 mm, UNLESS OTHERWISE SPECIFIED.

 SYMBOL OF QUALITY AN ISO 9001 COMPANY	JINDAL ALUMINIUM LTD. BANGALORE-560073 (INDIA)		DRAWN	KIRAN	DATE	26-09-2016
	1. ALL DIMENSIONS ARE IN mm. 2. ROUND OFF ALL SHARP CORNERS WITH 0.40 mm. 3. TOLERANCES WILL BE AS PER IS:3965-1981 UNLESS OTHERWISE SPECIFIED		CHECKED			
PARTY'S NAME	HAWK & CO, CHENNAI	SCALE	APPROVED	S.S. GARG	28-09-2016	
PARTY'S DRAWING No.	AS PER DRAWING	AREA mm ²				
ALLOY & TEMPER	HE9 WP	PERIMETER mm.				
DESCRIPTION	TILE LAYING SECTION	WEIGHT kg/m				
		DRAWING No.				
		SECTION No.				
		P-16388-1				
		S5094				
		28403				