

P-16303

S5109

28410

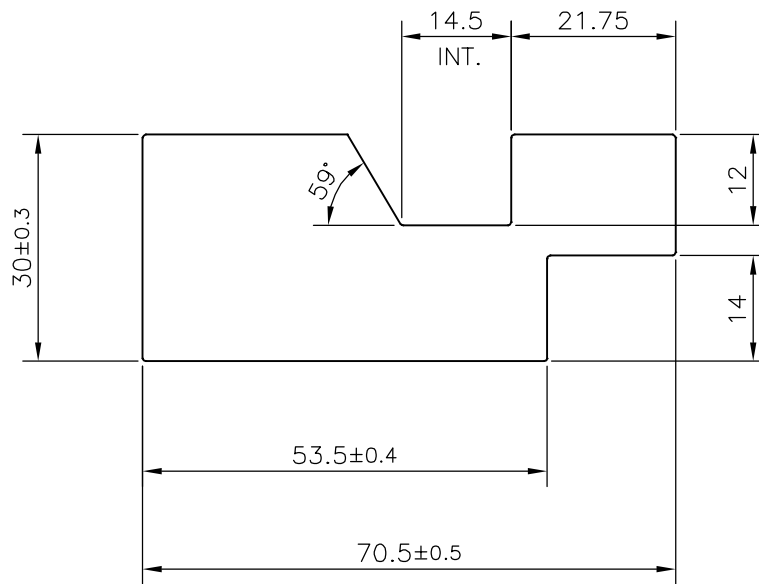

SYMBOL OF QUALITY
AN ISO 9001 COMPANY

JINDAL ALUMINIUM LTD.
BANGALORE-560073 (INDIA)

	NAME	DATE
DRAWN	KIRAN	07-09-2016
CHECKED		
APPROVED	B.NATARAJ	15-10-2016

1. ALL DIMENSIONS ARE IN mm.
2. ROUND OFF ALL SHARP CORNERS WITH 0.40 mm.
3. TOLERANCES WILL BE AS PER IS:3965-1981, UNLESS OTHERWISE SPECIFIED

SCALE	1:1
AREA mm ²	1659.609
PERIMETER mm.	218.375
WEIGHT kg/m	4.481

PARTY'S NAME SHREE EXPORT, JAMNAGAR

DRAWING No. SECTION No.

PARTY'S DRAWING No. 820-2-0233-01

P-16303

ALLOY & TEMPER 6061 T6

S5109

S5109

DESCRIPTION

MISC. SECTION

28410

28410