

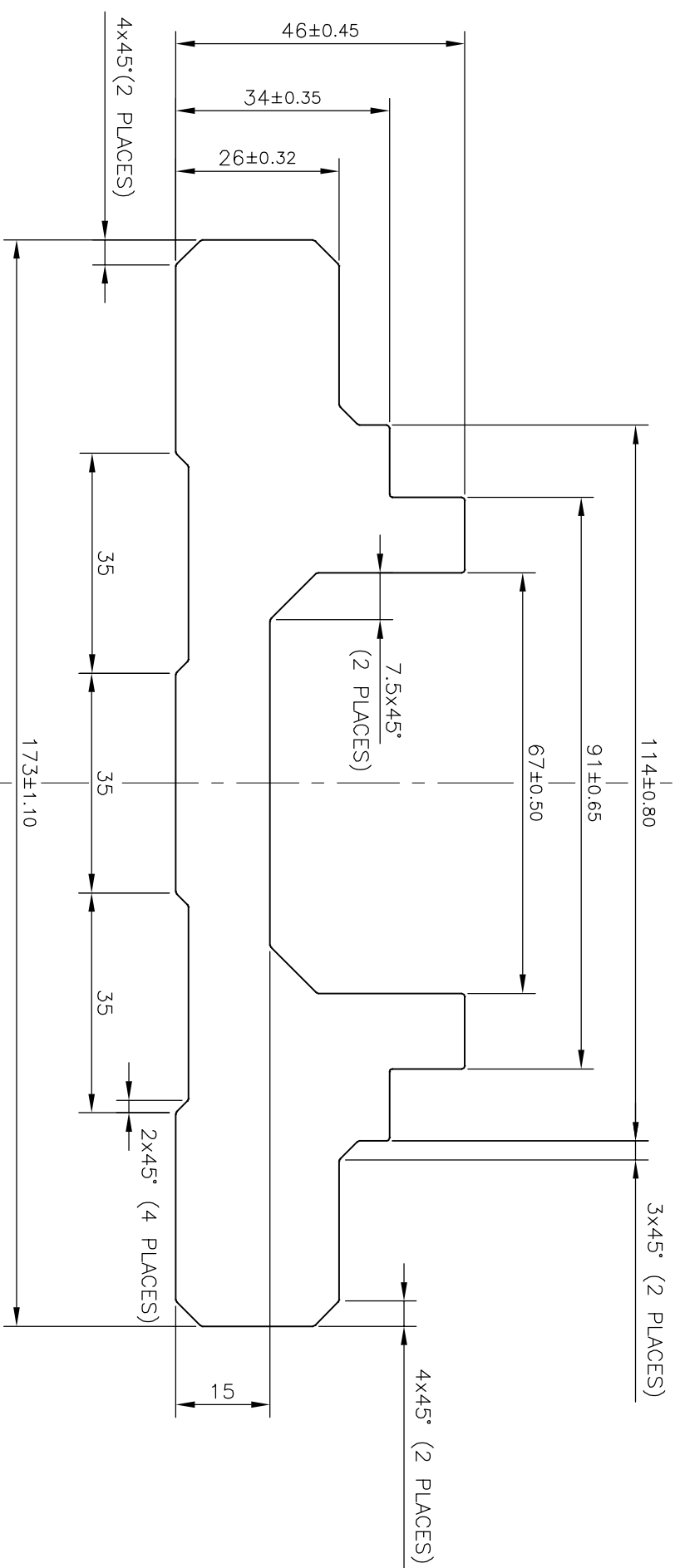

P-16620
S5242
28428



- NOTE: -**
1. STRAIGHTNESS = 1.70 mm/m
  2. TWIST & BEND = 1.70 mm/m
  3. FLATNESS = 0.86 mm.

 SYMBOL OF QUALITY AN ISO 9001 COMPANY		<b>JINDAL ALUMINIUM LTD.</b> BANGALORE-560073 (INDIA)	
1. ALL DIMENSIONS ARE IN mm. 2. ROUND OFF ALL SHARP CORNERS WITH 0.50 mm. 3. TOLERANCES WILL BE AS PER IS:3965-1981 UNLESS OTHERWISE SPECIFIED		SCALE	1:1
PARTY'S NAME		AREA mm <sup>2</sup>	4326.035
PARTY'S DRAWING No.		PERIMETER mm.	479.406
ALLOY & TEMPER		WEIGHT kg/m	11.680
DESCRIPTION		DRAWING No.	SECTION No.
6063 T6		P-16620	
MAIN BODY SECTION		S5242	S5242
		28428	28428