

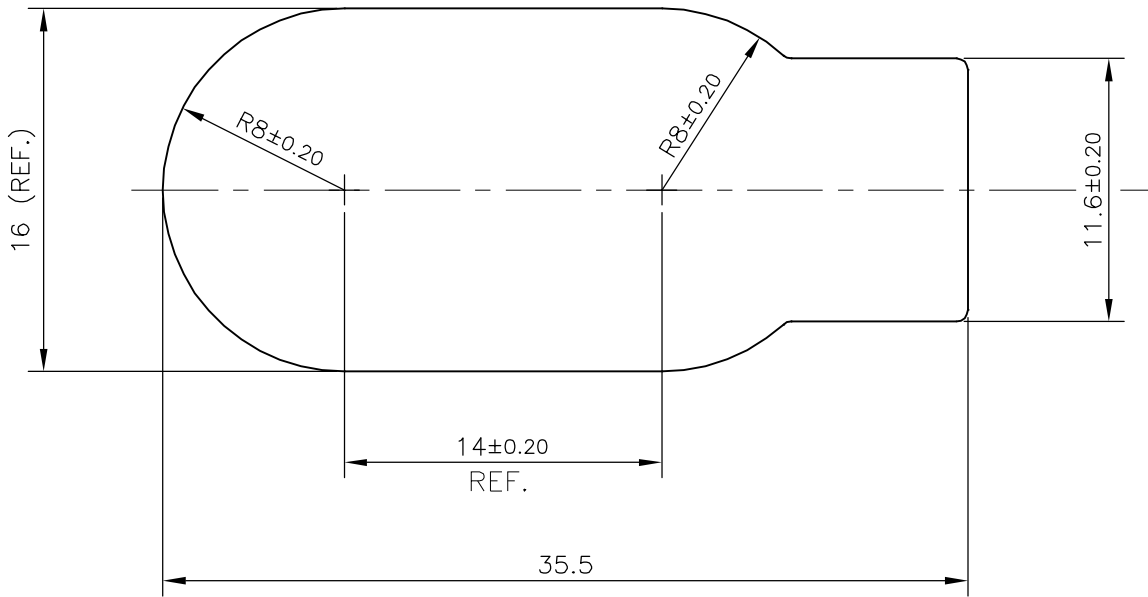

P-16609
S5270
28430

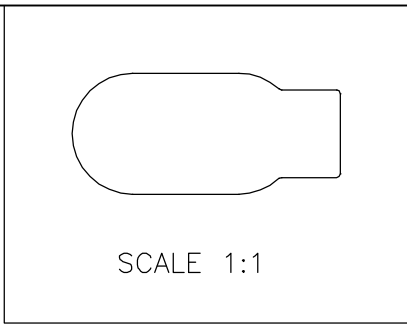

ISSUE-2:-
ALLOY CHANGED FROM 6005 T5 TO 6063 T6

 SYMBOL OF QUALITY AN ISO 9001 COMPANY	JINDAL ALUMINIUM LTD. BANGALORE-560073 (INDIA)	NAME	DATE
		DRAWN	J.P.KAUSHIK 03-07-2017
1. ALL DIMENSIONS ARE IN mm. 2. ROUND OFF ALL SHARP CORNERS WITH 0.50 mm. 3. TOLERANCES WILL BE AS PER IS:3965-1981, UNLESS OTHERWISE SPECIFIED		CHECKED	
		APPROVED	J.N.RAI 04-07-2017
PARTY'S NAME WONJIN AUTOPARTS INDIA PVT. LTD. CHENNAI		SCALE	3:1
		AREA mm ²	497.7
PARTY'S DRAWING No. T75339B-02		PERIMETER mm.	92.403
		WEIGHT kg/m	1.344
ALLOY & TEMPER 6063 T6		DRAWING No.	SECTION No.
		P-16609	
DESCRIPTION INLET FLANGE SECTION		S5270	S5270(ISSUE-2)
		28430	28430