

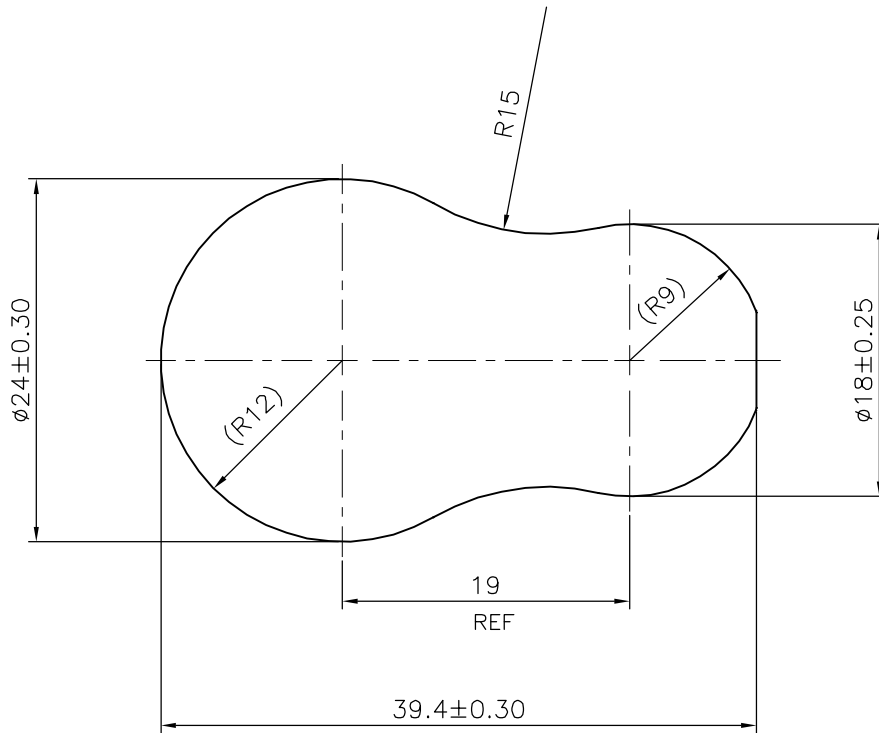

P-18515
S5951
28438

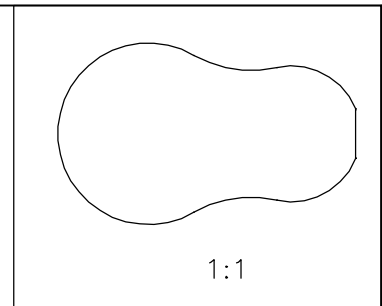

 SYMBOL OF QUALITY AN ISO 9001 COMPANY	JINDAL ALUMINIUM LTD. BANGALORE-560073 (INDIA)	NAME		DATE
		DRAWN	J.P.KAUSHIK	02-08-2018
1. ALL DIMENSIONS ARE IN mm. 2. ROUND OFF ALL SHARP CORNERS WITH 0.40 mm. 3. TOLERANCES WILL BE AS PER IS:3965-1981 UNLESS OTHERWISE SPECIFIED		CHECKED		
		APPROVED	B.NATARAJA	08-08-2018
PARTY'S NAME		SCALE		2:1
		AREA mm ²		719.171
PARTY'S DRAWING No.		PERIMETER mm.		105.202
		WEIGHT kg/m		1.942
ALLOY & TEMPER		DRAWING No.		SECTION No.
		P-18515		
DESCRIPTION		S5951		S5951
		28438		28438