

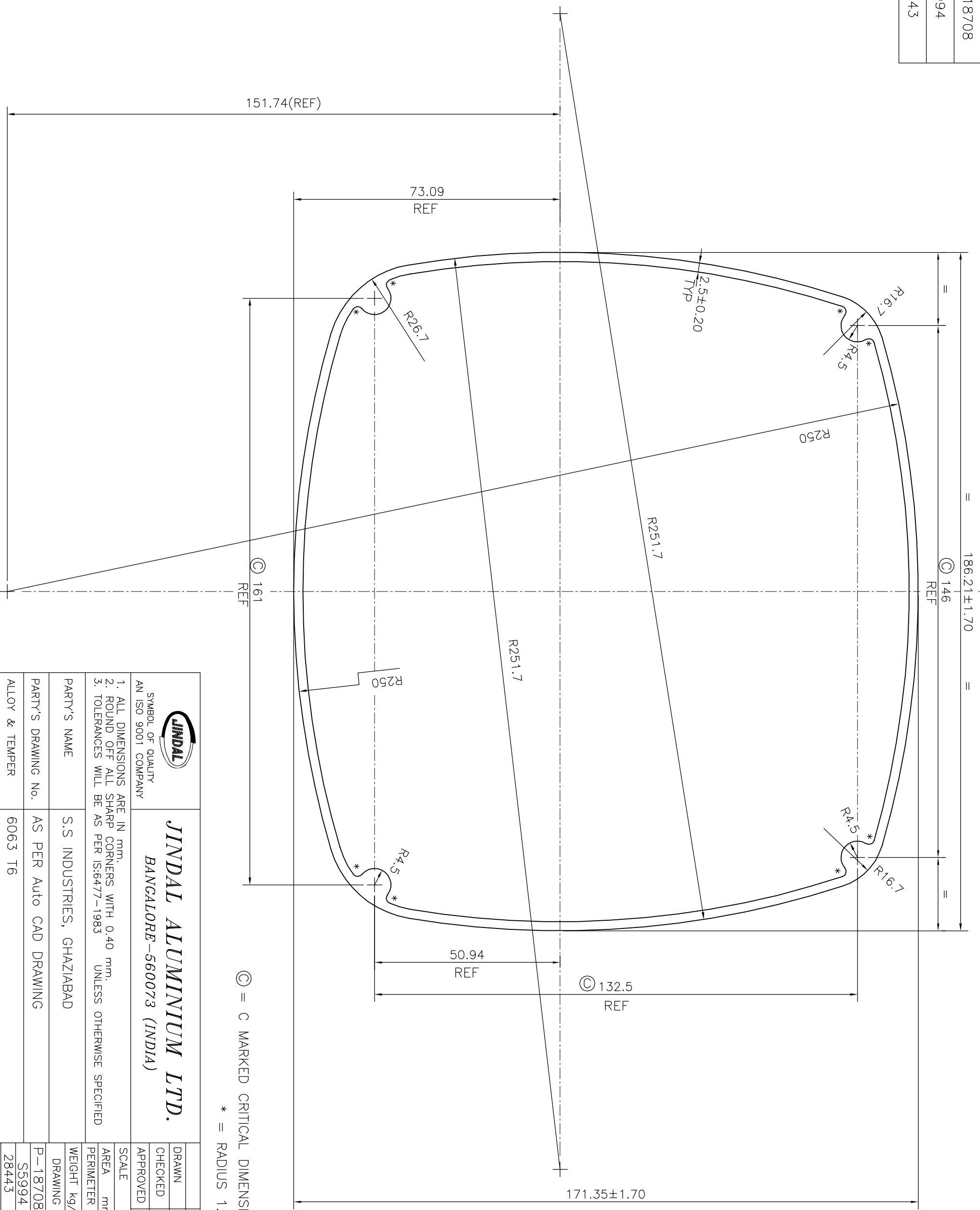

P-18708
S5994
28443



Ⓒ = C MARKED CRITICAL DIMENSIONS (3 PLACES)
 * = RADIUS 1.5 (8 PLACES)

 SYMBOL OF QUALITY AN ISO 9001 COMPANY		JINDAL ALUMINIUM LTD. BANGALORE-560073 (INDIA)		NAME	DATE
1. ALL DIMENSIONS ARE IN mm. 2. ROUND OFF ALL SHARP CORNERS WITH 0.40 mm. 3. TOLERANCES WILL BE AS PER IS:6477-1983 UNLESS OTHERWISE SPECIFIED		DRAWN	J.P.KAUSHIK	29-09-2018	
PARTY'S NAME	S.S INDUSTRIES, GHAZIABAD	CHECKED			
PARTY'S DRAWING No.	AS PER Auto CAD DRAWING	APPROVED	B. NATARAJA	04-10-2018	
ALLOY & TEMPER	6063 T6	SCALE		1:1	
DESCRIPTION	MAIN BODY FOR VACUUM CLEANER	AREA mm ²		1729.34	
		PERIMETER mm.		618.288	
		WEIGHT kg/m		4.669	
		DRAWING No.		SECTION No.	
		P-18708		-	
		S5994		S5994	
		28443		28443	