

P-15664-1

X1995

28447

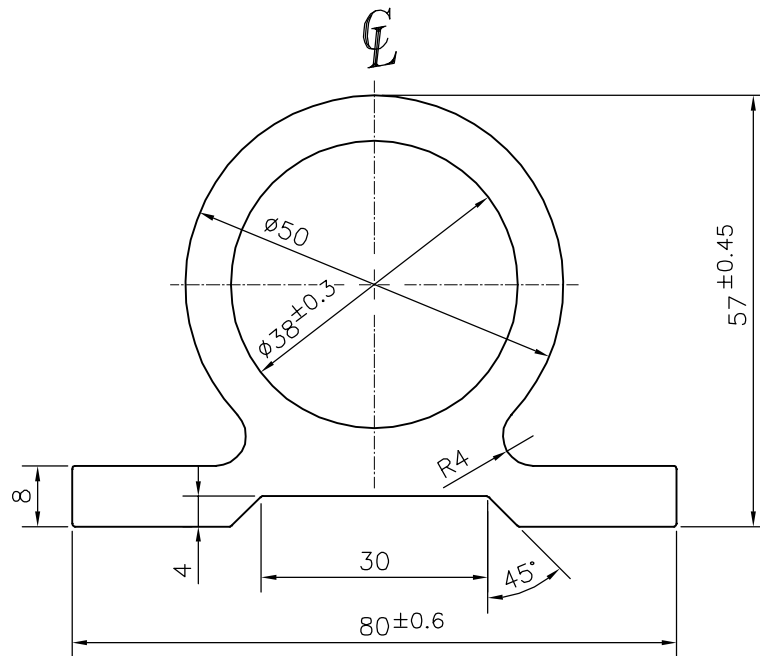

1. STRAIGHTNESS=1.0mm/M
2. TWIST=1.0mm/M
3. ANGULARITY= ±2°
4. FLATNESS =0.007xWIDTH



SYMBOL OF QUALITY
AN ISO 9001 COMPANY

JINDAL ALUMINIUM LTD.
BANGALORE-560073 (INDIA)

	NAME	DATE
DRAWN	PARVESH	19-03-2016
CHECKED		
APPROVED	S.S. GARG	20-04-2016
SCALE		1:1
AREA mm ²		1377.819
PERIMETER mm.		271.803
WEIGHT kg/m		3.720
DRAWING No.	SECTION No.	
P-15664-1	-	
X1995	X1995	
28447	28447	

1. ALL DIMENSIONS ARE IN mm.
2. ROUND OFF ALL SHARP CORNERS WITH 0.40 mm.
3. TOLERANCES WILL BE AS PER IS:6477-1983 , UNLESS OTHERWISE SPECIFIED

PARTY'S NAME	JARRA CNC PRODUCTS, HOSUR
PARTY'S DRAWING No.	SOL GR611 924
ALLOY & TEMPER	6063 T5
DESCRIPTION	MISC. SECTION