

P-15666-1

X1997

28449

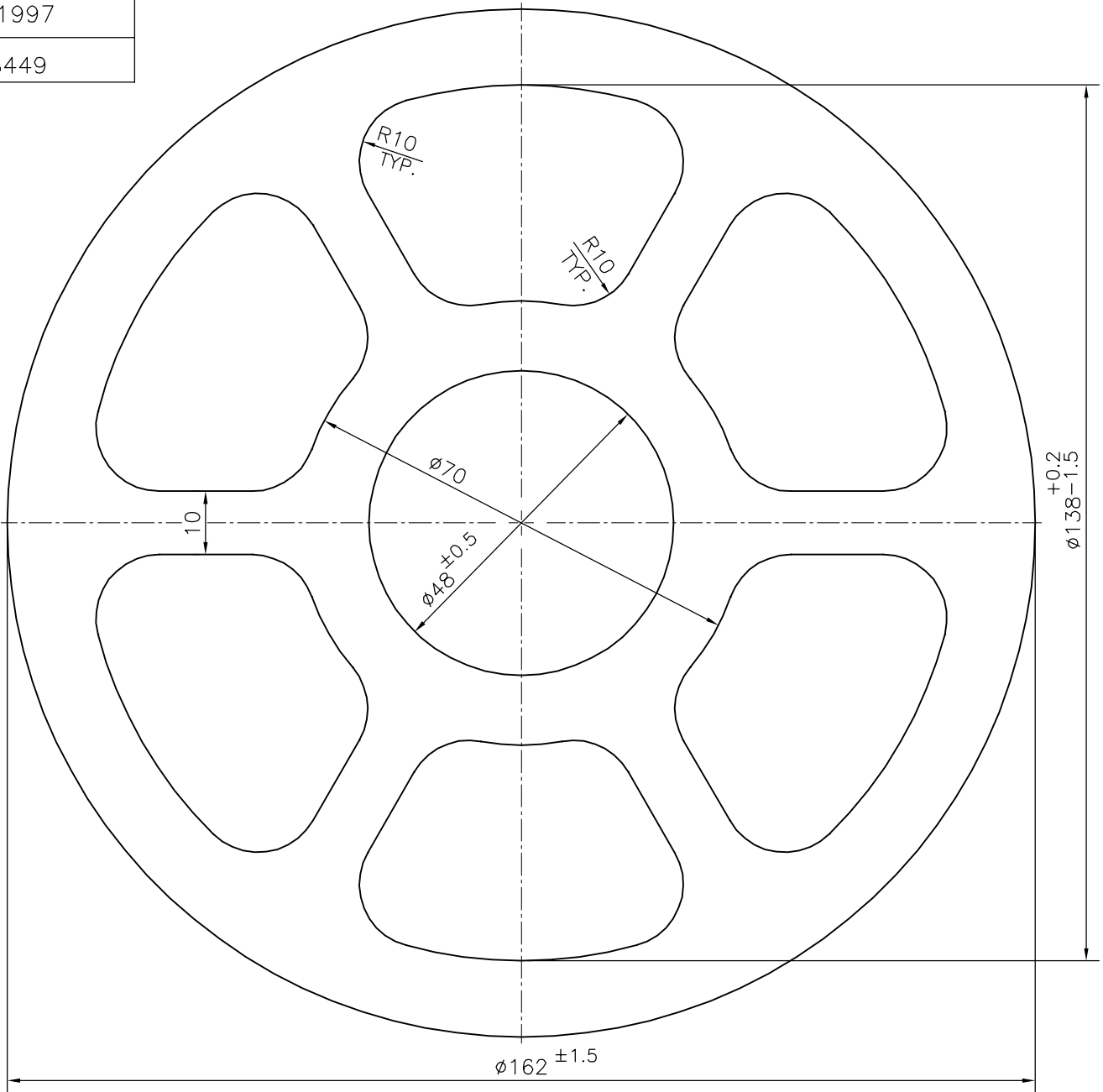

ISSUE-2

TOLERANCE ADDED ON DIMENSION $\varnothing 138 \text{ mm. } \begin{matrix} +0.2 \\ -1.5 \end{matrix}$

1. STRAIGHTNESS=1.0mm/M
2. TWIST=1.0mm/M
3. ANGULARITY= $\pm 2^\circ$
4. FLATNESS =0.007xWIDTH



SYMBOL OF QUALITY
AN ISO 9001 COMPANY

JINDAL ALUMINIUM LTD.
BANGALORE-560073 (INDIA)

	NAME	DATE
DRAWN	PARVESH	06-07-2016
CHECKED		
APPROVED	S.S. GARG	12-07-2016
SCALE		1:1
AREA mm ²		10264.769
PERIMETER mm.		508.938
WEIGHT kg/m		27.715
DRAWING No.	SECTION No.	
P-15666-1	-	
X1997	X1997-ISSUE-2	
28449	28449	

1. ALL DIMENSIONS ARE IN mm.
2. ROUND OFF ALL SHARP CORNERS WITH 0.40 mm.
3. TOLERANCES WILL BE AS PER IS:6477-1983 , UNLESS OTHERWISE SPECIFIED

PARTY'S NAME	JARRA CNC PRODUCTS, HOSUR
PARTY'S DRAWING No.	SOL-WF- 111 708
ALLOY & TEMPER	6063 T5
DESCRIPTION	MISC. SECTION