

P-15721
X2002
28454

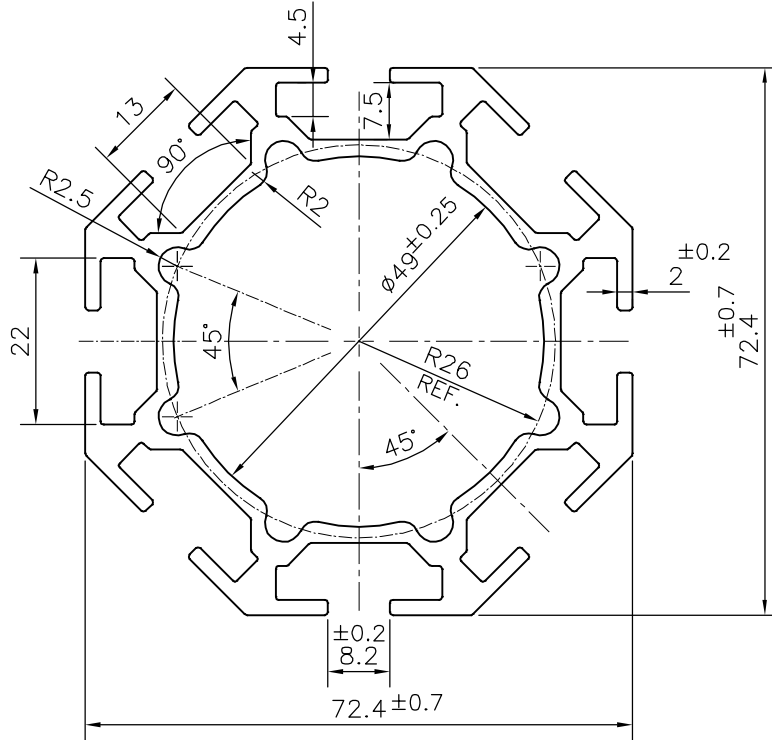

ISSUE-2

TOLERANCE CHANGED ON DIMENSION 49 mm.
±0.5 TO ±0.25

1. STRAIGHTNESS=1.0mm/M
2. TWIST=1.0mm/M
3. ANGULARITY= ±2°
4. FLATNESS =0.007xWIDTH

 SYMBOL OF QUALITY AN ISO 9001 COMPANY	JINDAL ALUMINIUM LTD. BANGALORE-560073 (INDIA)	NAME		DATE
		DRAWN	PARVESH	06-07-2016
1. ALL DIMENSIONS ARE IN mm. 2. ROUND OFF ALL SHARP CORNERS WITH 0.40 mm. 3. TOLERANCES WILL BE AS PER IS:6477-1983 , UNLESS OTHERWISE SPECIFIED		CHECKED		
		APPROVED	S.S. GARG	12-07-2016
PARTY'S NAME JARRA CNC PRODUCTS, HOSUR		SCALE		1:1
		AREA mm ²		999.617
PARTY'S DRAWING No. AS PER AUTOCAD DRAWING-SOL-GR4		PERIMETER mm.		572.919
		WEIGHT kg/m		2.699
ALLOY & TEMPER 6063 T5		DRAWING No.		P-15721
		SECTION No.		-
DESCRIPTION INDUSTRIAL SECTION-ROTATIONAL CLEANING CYLINDER PROFILE		X2002		X2002-ISSUE-2
		28454		28454