

P-18516

S5952

28455

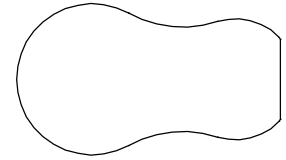

1:1

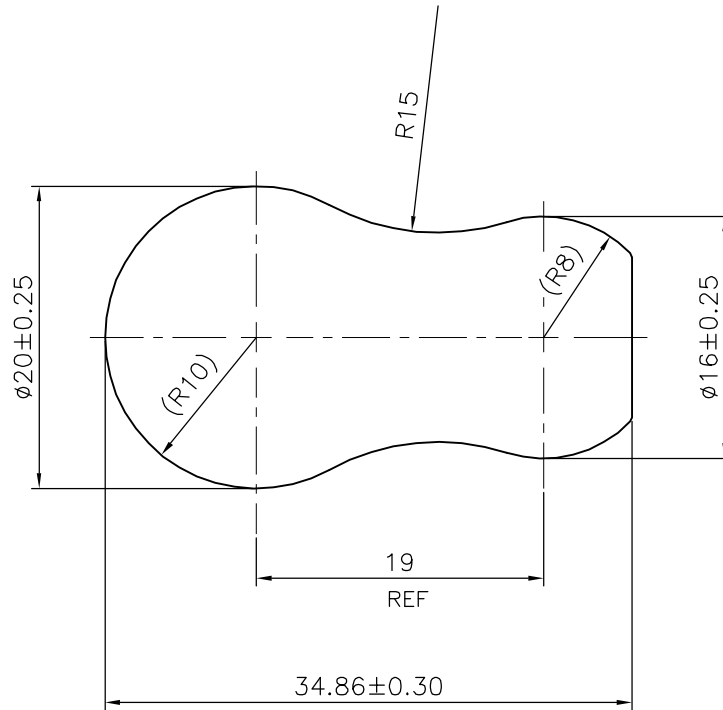

SYMBOL OF QUALITY
AN ISO 9001 COMPANY

JINDAL ALUMINIUM LTD.
BANGALORE-560073 (INDIA)

	NAME	DATE
DRAWN	J.P.KAUSHIK	02-08-2018
CHECKED		
APPROVED	B.NATARAJA	08-08-2018
SCALE		2:1
AREA mm ²		545.695
PERIMETER mm.		94.692
WEIGHT kg/m		1.473
DRAWING No.	SECTION No.	
P-18516		
S5952	S5952	
28455	28455	

1. ALL DIMENSIONS ARE IN mm.
2. ROUND OFF ALL SHARP CORNERS WITH 0.40 mm.
3. TOLERANCES WILL BE AS PER IS:3965-1981 UNLESS OTHERWISE SPECIFIED

PARTY'S NAME	SHUBHANGAD INDUSTRIES, PUNE
PARTY'S DRAWING No.	70.17559 REV-0001
ALLOY & TEMPER	6060 T66
DESCRIPTION	FIAT OUTLET FLANGE