

P-17269-1

S5430

28465

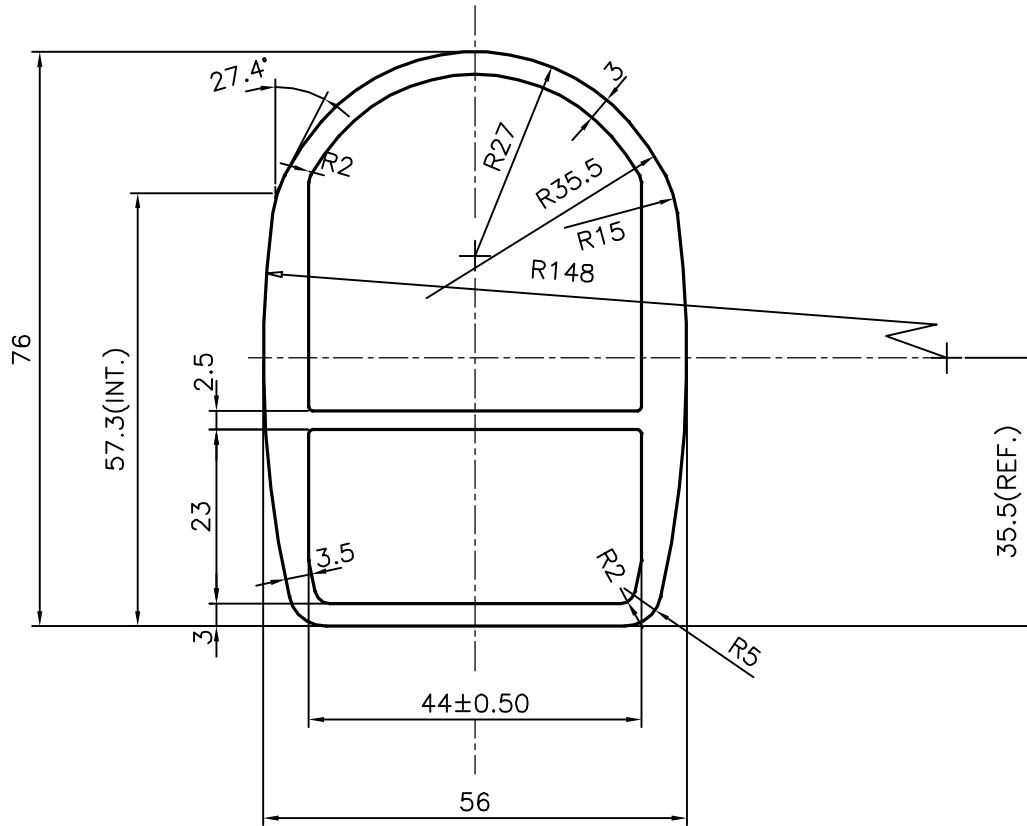

TOLERANCES ON OVERALL DIMENSIONS OF HOLLOW SECTIONS

UPTO 20.0mm - ±0.30	UPTO 80.0mm - ±0.70	UPTO 180.0mm - ±1.27	1. STRAIGHTNESS=1.7mm/M 2. TWIST=1.7mm/M 3. ANGULARITY= ±2° 4. FLATNESS =0.006xWIDTH
UPTO 30.0mm - ±0.38	UPTO 100.0mm - ±0.80	UPTO 200.0mm - ±1.40	
UPTO 40.0mm - ±0.45	UPTO 120.0mm - ±0.90	UPTO 225.0mm - ±1.52	
UPTO 50.0mm - ±0.52	UPTO 140.0mm - ±1.00		
UPTO 60.0mm - ±0.60	UPTO 160.0mm - ±1.14		



SYMBOL OF QUALITY
AN ISO 9001 COMPANY

JINDAL ALUMINIUM LTD.
BANGALORE-560073 (INDIA)

	NAME	DATE
DRAWN	J.P.KAUSHIK	16-06-2017
CHECKED		
APPROVED	B.NATARAJA	21-06-2017
SCALE		1:1
AREA mm ²		998.699
PERIMETER mm.		228.846
WEIGHT kg/m		2.696
DRAWING No.	SECTION No.	
P-17269-1	-	
S5430	S5430	
28465	28465	

1. ALL DIMENSIONS ARE IN mm.
2. ROUND OFF ALL SHARP CORNERS WITH 0.50 mm.
3. TOLERANCES WILL BE AS PER IS:6477-1983 , UNLESS OTHERWISE SPECIFIED

PARTY'S NAME	CONFIDENT DENTAL EQUIPMENTS LTD., BANGALORE
PARTY'S DRAWING No.	R&DZ-14658 REV.01
ALLOY & TEMPER	6063 T6
DESCRIPTION	HINGE OUTER BODY SECTION