

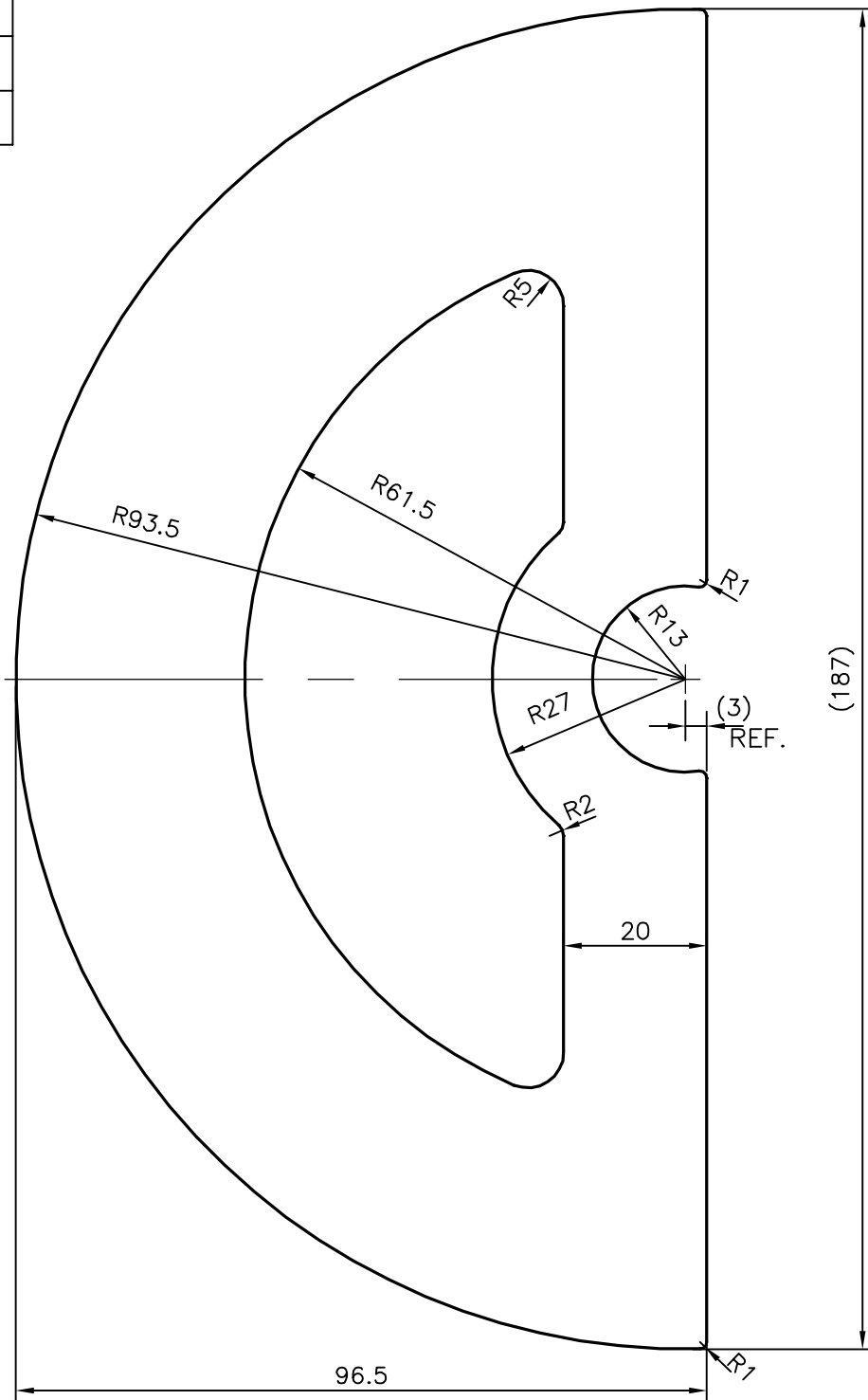

P-17657-1
S5598
28483



TOLERANCES ON OVERALL WIDTHS & WIDTHS ACROSS FLATS OF BARS, & REGULAR SECTIONS

UPTO 6.40mm - ±0.20	UPTO 32.0mm - ±0.38	UPTO 120.0mm - ±0.85	UPTO 320.00mm - ±1.70
UPTO 10.0mm - ±0.23	UPTO 50.0mm - ±0.46	UPTO 160.0mm - ±1.02	
UPTO 12.0mm - ±0.25	UPTO 60.0mm - ±0.53	UPTO 200.0mm - ±1.14	
UPTO 16.0mm - ±0.28	UPTO 80.0mm - ±0.69	UPTO 250.0mm - ±1.40	
UPTO 25.0mm - ±0.30	UPTO 100.0mm - ±0.75	UPTO 300.0mm - ±1.65	

 SYMBOL OF QUALITY AN ISO 9001 COMPANY	<b>JINDAL ALUMINIUM LTD.</b> BANGALORE-560073 (INDIA)	DRAWN	J.P.KAUSHIK	DATE	18-11-2017
		CHECKED			
		APPROVED	B.NATARAJA	DATE	25-11-2017
1. ALL DIMENSIONS ARE IN mm. 2. ROUND OFF ALL SHARP CORNERS WITH 0.40 mm. 3. TOLERANCES WILL BE AS PER,IS:6477-1983 UNLESS OTHERWISE SPECIFIED		SCALE		1:1	
		AREA mm <sup>2</sup>		10388.459	
		PERIMETER mm.		506.121	
		WEIGHT kg/m		28.049	
		DRAWING No.		SECTION No.	
PARTY'S NAME		ROOTS INDUSTRIES INDIA LTD., COIMBATORE		P-17657-1	
PARTY'S DRAWING No.		AS PER DRAWING		-	
ALLOY & TEMPER		6061 T6		S5598	
				28483	
DESCRIPTION		MEDICAL EQUIPMENT SECTION			