

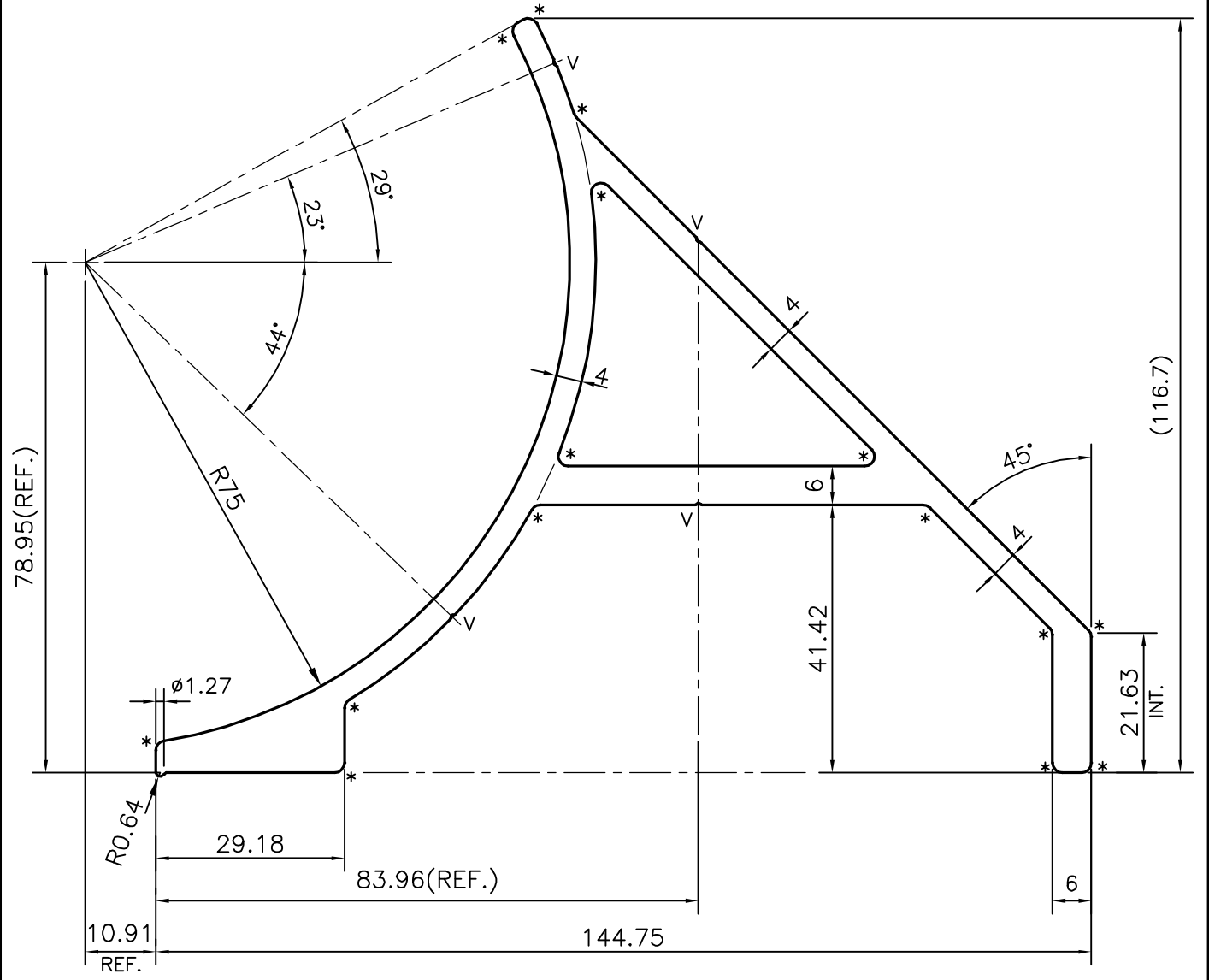

P-17742
S5636
28493



V = V GROOVE 0.3x90°(4 PLACES)
 * = 1.5 RADIUS (15 PLACES)

 SYMBOL OF QUALITY AN ISO 9001 COMPANY	JINDAL ALUMINIUM LTD. BANGALORE-560073 (INDIA)	DRAWN	NAME	DATE
		CHECKED	J.P.KAUSHIK	28-12-2017
1. ALL DIMENSIONS ARE IN mm. 2. ROUND OFF ALL SHARP CORNERS WITH 0.40 mm. 3. TOLERANCES WILL BE AS PER,IS:6477-1983 UNLESS OTHERWISE SPECIFIED		APPROVED	B.NATARAJA	08-01-2018
		SCALE		1:1
PARTY'S NAME ENERCON ASIA PACIFIC SYSTEMS PVT. LTD., BANGALORE		AREA	mm ²	1636.632
		PERIMETER	mm.	501.651
PARTY'S DRAWING No. AL7150-01 REV. B		WEIGHT	kg/m	4.419
		DRAWING No.		SECTION No.
ALLOY & TEMPER 6063 T5		P-17742		-
		S5636		S5636
DESCRIPTION SHROUD SECTION		28493		28493