

P-17886

S5703

28495

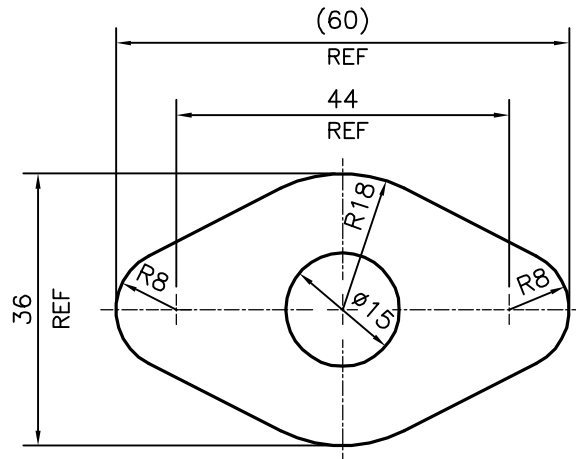

TOLERANCES ON OVERALL DIMENSIONS OF HOLLOW SECTIONS

UPTO 20.0mm - ±0.30
 UPTO 30.0mm - ±0.38
 UPTO 40.0mm - ±0.45
 UPTO 50.0mm - ±0.52
 UPTO 60.0mm - ±0.60

UPTO 80.0mm - ±0.70
 UPTO 100.0mm - ±0.80
 UPTO 120.0mm - ±0.90
 UPTO 140.0mm - ±1.00
 UPTO 160.0mm - ±1.14

UPTO 180.0mm - ±1.27
 UPTO 200.0mm - ±1.40
 UPTO 225.0mm - ±1.52

1. STRAIGHTNESS=1.7mm/M
 2. TWIST=1.7mm/M
 3. ANGULARITY= ±2°
 4. FLATNESS =0.006xWIDTH



SYMBOL OF QUALITY
 AN ISO 9001 COMPANY

JINDAL ALUMINIUM LTD.
 BANGALORE-560073 (INDIA)

	NAME	DATE
DRAWN	J.P.KAUSHIK	16-02-2018
CHECKED		
APPROVED	B.NATARAJ	03-03-2018

1. ALL DIMENSIONS ARE IN mm.
2. ROUND OFF ALL SHARP CORNERS WITH 0.40 mm.
3. TOLERANCES WILL BE AS PER IS:6477-1983 , UNLESS OTHERWISE SPECIFIED

SCALE	1:1
AREA mm ²	1288.703
PERIMETER mm.	147.524
WEIGHT kg/m	3.479

PARTY'S NAME	WONJIN AUTOPARTS INDIA PVT. LTD., CHENNAI
PARTY'S DRAWING No.	AD201551/E
ALLOY & TEMPER	6061 T6
DESCRIPTION	FLANGE-DISCHARGE SECTION

DRAWING No.	SECTION No.
P-17886	-
S5703	S5703
28495	28495