

P-21436

28527

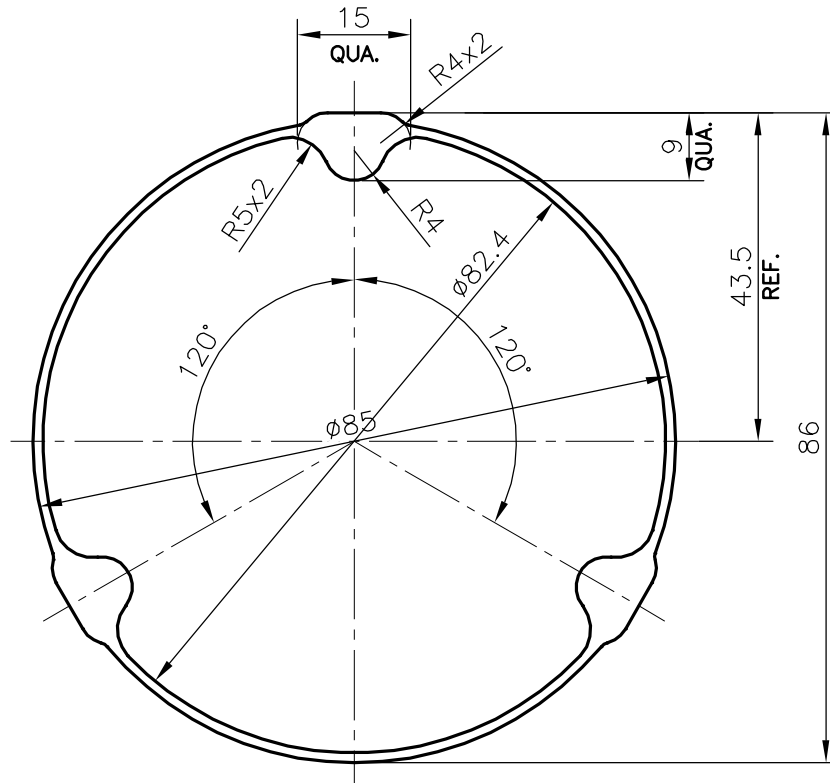

SCALE: - 1:1

TOLERANCES ON OVERALL DIMENSIONS OF HOLLOW SECTIONS

UPTO 20.0mm - ±0.30	UPTO 80.0mm - ±0.70	UPTO 180.0mm - ±1.27	1. STRAIGHTNESS=1.7mm/M 2. TWIST=1.7mm/M 3. ANGULARITY= ±2° 4. FLATNESS =0.006xWIDTH
UPTO 30.0mm - ±0.38	UPTO 100.0mm - ±0.80	UPTO 200.0mm - ±1.40	
UPTO 40.0mm - ±0.45	UPTO 120.0mm - ±0.90	UPTO 225.0mm - ±1.52	
UPTO 50.0mm - ±0.52	UPTO 140.0mm - ±1.00		
UPTO 60.0mm - ±0.60	UPTO 160.0mm - ±1.14		



SYMBOL OF QUALITY  
AN ISO 9001 COMPANY

**JINDAL ALUMINIUM LTD.**  
BANGALORE-560073 (INDIA)

	NAME	DATE
DRAWN	DARPAN	07-09-2020
CHECKED		
APPROVED	B.NATARAJA	24-09-2020

- ALL DIMENSIONS ARE IN mm.
- ROUND OFF ALL SHARP CORNERS WITH 0.40 mm.
- TOLERANCES WILL BE AS PER **IS:6477-1983**, UNLESS OTHERWISE SPECIFIED

SCALE	1:1
AREA mm <sup>2</sup>	551.945
PERIMETER mm.	269.448
WEIGHT kg/m	1.490

PARTY'S NAME	CONFIDENT DENTAL EQUIPMENTS PVT. LTD., BANGALURU
PARTY'S DRAWING No.	R&D Z-17458
ALLOY & TEMPER	63400 WP
DESCRIPTION	OUTER TUBE SPOT LIGHT SECTION

DRAWING No.	SECTION No.
P-21436	-
28527	28527