

P-18143

S5798

28537

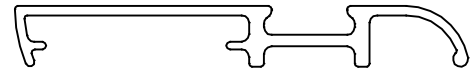

1:1

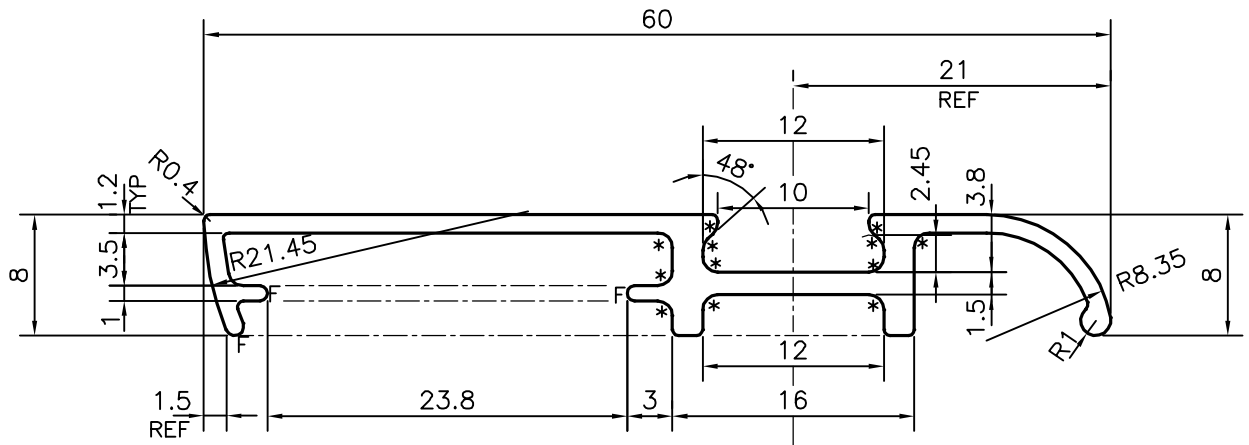

* = 1.0 RADIUS (12 PLACES)

F= FULL RADIUS (3 PLACES)



SYMBOL OF QUALITY
AN ISO 9001 COMPANY

JINDAL ALUMINIUM LTD.
BANGALORE-560073 (INDIA)

	NAME	DATE
DRAWN	J.P.KAUSHIK	24-04-2018
CHECKED		
APPROVED	B.NATARAJA	26-04-2018
SCALE		2:1
AREA mm ²		125.856
PERIMETER mm.		176.495
WEIGHT kg/m		0.340
DRAWING No.	SECTION No.	
P-18143	-	
S5798	S5798	
28537	28537	

1. ALL DIMENSIONS ARE IN mm.
2. ROUND OFF ALL SHARP CORNERS WITH 0.40 mm.
3. TOLERANCES WILL BE AS PER IS:3965-1981 , UNLESS OTHERWISE SPECIFIED

PARTY'S NAME	ALUCRAFT, BANGALORE
PARTY'S DRAWING No.	AS PER DRAWING
ALLOY & TEMPER	6063 T6
DESCRIPTION	SKIRTING PROFILE TYPE-06