

P-18150

S5803

28539

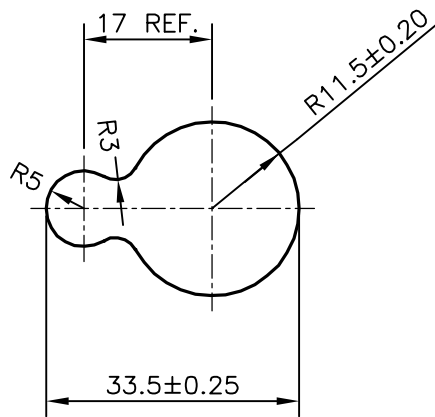

SYMBOL OF QUALITY
AN ISO 9001 COMPANY

JINDAL ALUMINIUM LTD.
BANGALORE-560073 (INDIA)

	NAME	DATE
DRAWN	J.P.KAUSHIK	26-04-2018
CHECKED		
APPROVED	B.NATARAJA	30-04-2018
SCALE		1:1
AREA mm ²		504.959
PERIMETER mm.		92.052
WEIGHT kg/m		1.363
DRAWING No.	SECTION No.	
P-18150	-	
S5803	S5803	
28539	28539	

1. ALL DIMENSIONS ARE IN mm.
2. ROUND OFF ALL SHARP CORNERS WITH 0.40 mm.
3. TOLERANCES WILL BE AS PER IS:3965-1981 , UNLESS OTHERWISE SPECIFIED

PARTY'S NAME	SHUBHANGAD INDUSTRIES, PUNE
PARTY'S DRAWING No.	70.35600 REV-0001
ALLOY & TEMPER	6060 T6
DESCRIPTION	MISC. SECTION