

P-18235

S5870

28545

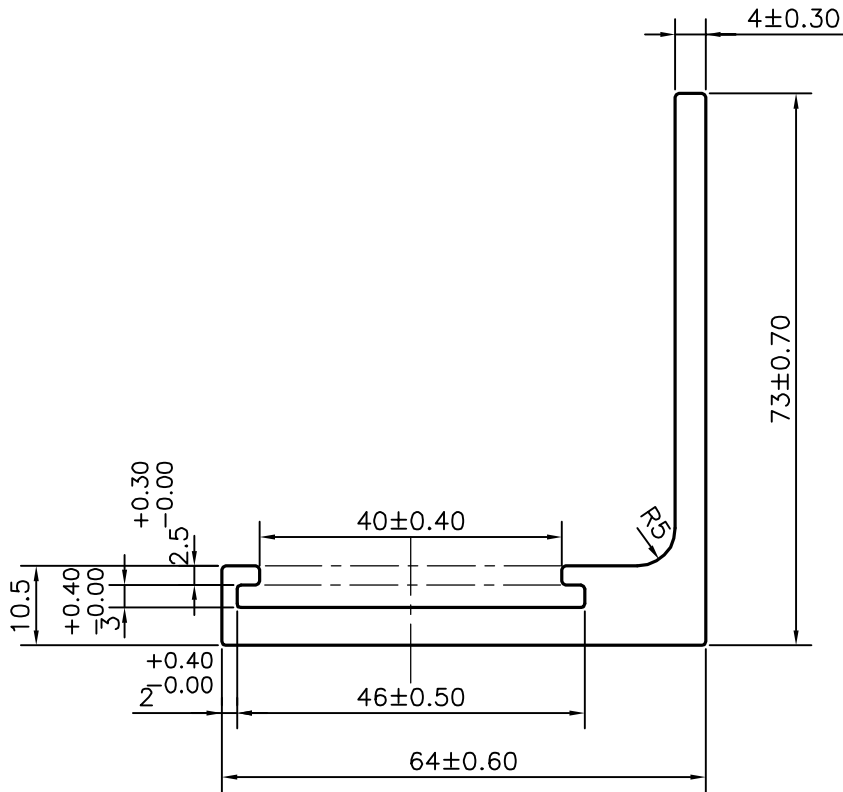

UNSPECIFIED RADIUS 0.5 mm



SYMBOL OF QUALITY
AN ISO 9001 COMPANY

JINDAL ALUMINIUM LTD.
BANGALORE-560073 (INDIA)

	NAME	DATE
DRAWN	J.P.KAUSHIK	18-05-2018
CHECKED		
APPROVED	B.NATARAJA	01-06-2018

1. ALL DIMENSIONS ARE IN mm.
2. ROUND OFF ALL SHARP CORNERS WITH 0.40 mm.
3. TOLERANCES WILL BE AS PER,IS:3965-1981 UNLESS OTHERWISE SPECIFIED

SCALE	1:1
AREA mm ²	689.097
PERIMETER mm.	292.064
WEIGHT kg/m	1.861

PARTY'S NAME	JAYANITA EXPORTS PVT. LTD., GREATER NOIDA
PARTY'S DRAWING No.	AS PER DRAWING
ALLOY & TEMPER	6063 T6
DESCRIPTION	SMALL SINGLE BRACKET SECTION

DRAWING No.	SECTION No.
P-18235	-
S5870	S5870
28545	28545