

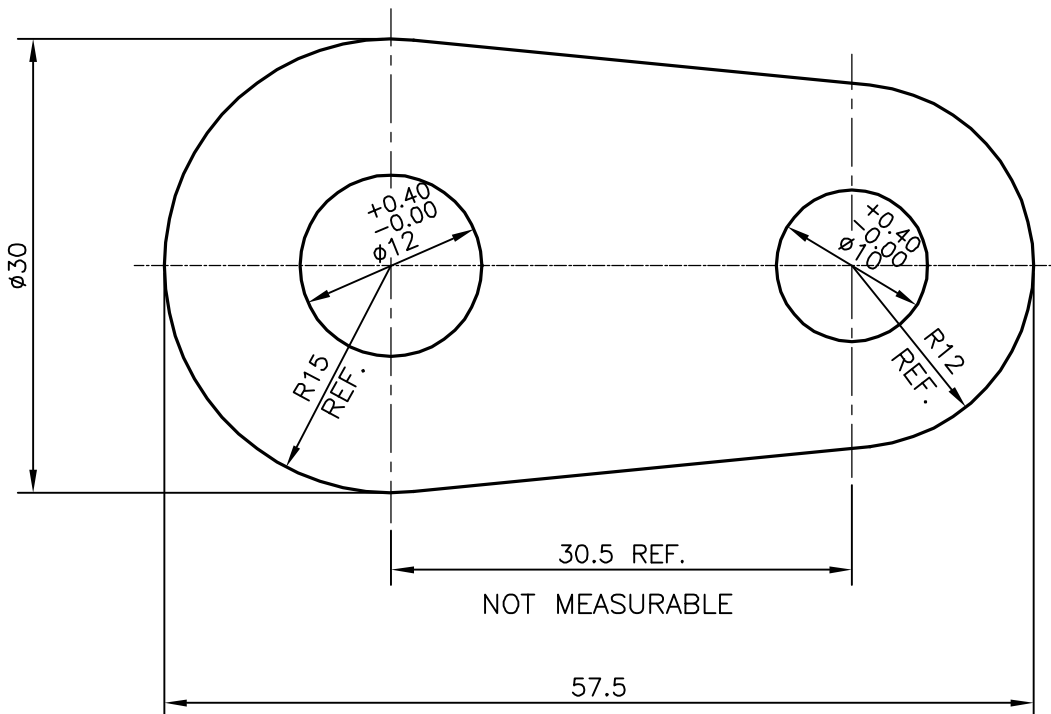

P-18266
S5887
28547

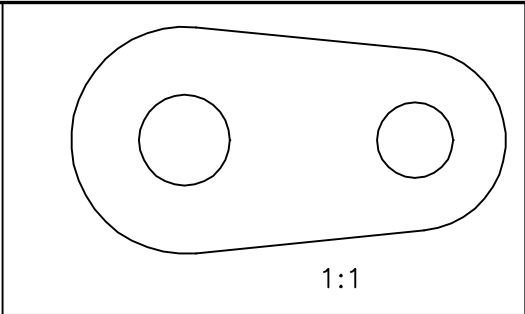

 SYMBOL OF QUALITY AN ISO 9001 COMPANY	<b>JINDAL ALUMINIUM LTD.</b> BANGALORE-560073 (INDIA)	NAME		DATE
		DRAWN	J.P.KAUSHIK	24-05-2018
1. ALL DIMENSIONS ARE IN mm. 2. ROUND OFF ALL SHARP CORNERS WITH 0.40 mm. 3. TOLERANCES WILL BE AS PER IS:6477-1983 , UNLESS OTHERWISE SPECIFIED		CHECKED		
		APPROVED	B.NATARAJA	13-06-2018
PARTY'S NAME WONJIN AUTOPARTS INDIA PVT. LTD. CHENNAI		SCALE		2:1
		AREA mm <sup>2</sup>		1215.474
PARTY'S DRAWING No. 52497792/E		PERIMETER mm.		146.118
		WEIGHT kg/m		3.282
ALLOY & TEMPER 6061 T6		DRAWING No.		SECTION No.
		P-18266		-
DESCRIPTION FLANGE-FITTING BLOCK		S5887		S5887
		28547		28547