

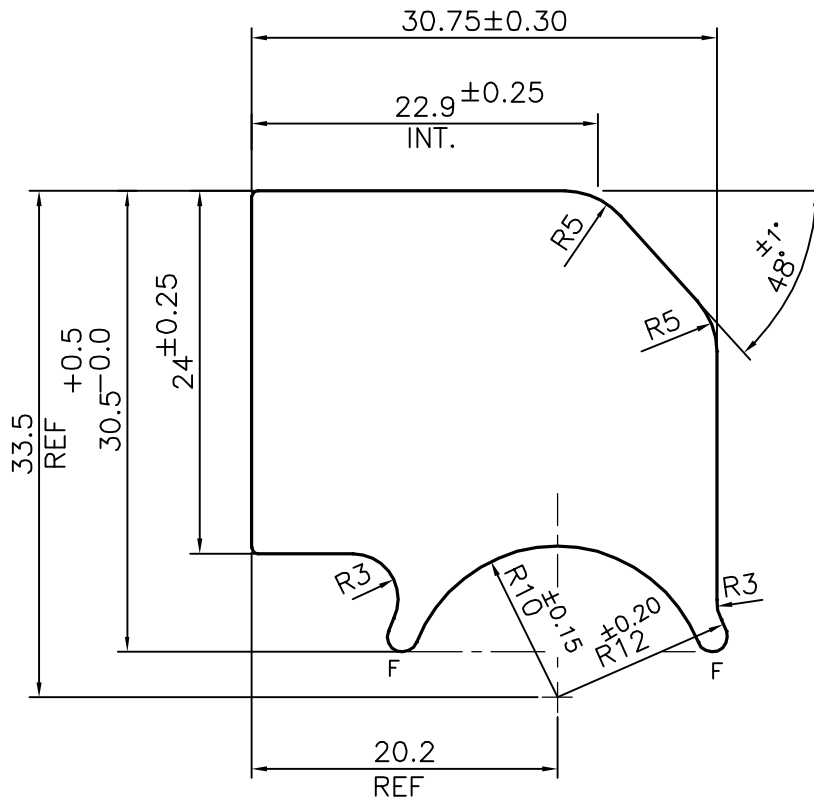

P-18061-1
S5896
28548

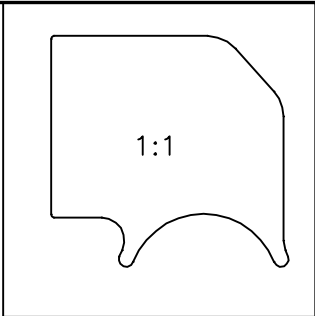

F = FULL RADIUS (2 PLACES)

 SYMBOL OF QUALITY AN ISO 9001 COMPANY	JINDAL ALUMINIUM LTD. BANGALORE-560073 (INDIA)	NAME	DATE
		DRAWN	J.P.KAUSHIK
		CHECKED	
		APPROVED	B.NATARAJA
			23-06-2018
1. ALL DIMENSIONS ARE IN mm. 2. ROUND OFF ALL SHARP CORNERS WITH 0.40 mm. 3. TOLERANCES WILL BE AS PER IS:3965-1981 UNLESS OTHERWISE SPECIFIED		SCALE	2:1
		AREA mm ²	745.841
		PERIMETER mm.	122.289
PARTY'S NAME	PYN PRECISION COMPONENTS, FARIDABAD	WEIGHT kg/m	2.014
PARTY'S DRAWING No.	HC839G6C1A-02	DRAWING No.	SECTION No.
ALLOY & TEMPER	6005 T5	P-18061-1	-
DESCRIPTION	INLET FLANGE SECTION	S5896	S5896
		28548	28548