

P-18062-1

S5897

28549

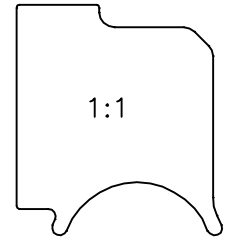

1:1

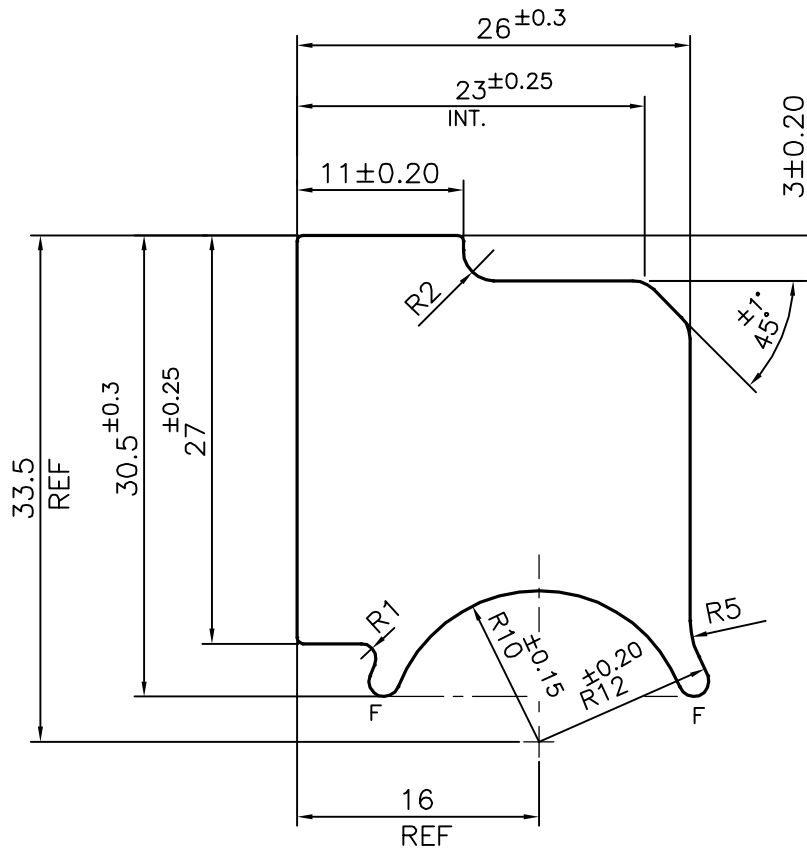

F = FULL RADIUS (2 PLACES)



SYMBOL OF QUALITY
AN ISO 9001 COMPANY

JINDAL ALUMINIUM LTD.
BANGALORE-560073 (INDIA)

	NAME	DATE
DRAWN	J.P.KAUSHIK	14-06-2018
CHECKED		
APPROVED	B.NATARAJA	23-06-2018
SCALE		2:1
AREA mm ²		631.543
PERIMETER mm.		116.321
WEIGHT kg/m		1.705
DRAWING No.	SECTION No.	
P-18062-1	-	
S5897	S5897	
28549	28549	

1. ALL DIMENSIONS ARE IN mm.
2. ROUND OFF ALL SHARP CORNERS WITH 0.40 mm.
3. TOLERANCES WILL BE AS PER IS:3965-1981 UNLESS OTHERWISE SPECIFIED

PARTY'S NAME	PYN PRECISION COMPONENTS, FARIDABAD
PARTY'S DRAWING No.	HC840G6C1A-02
ALLOY & TEMPER	6005 T5
DESCRIPTION	OUTLET FLANGE SECTION