

P-18363

S5915

28550

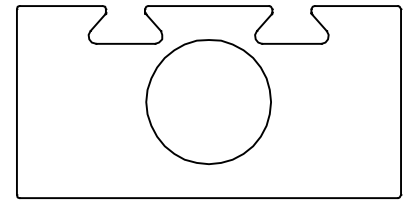

1:1

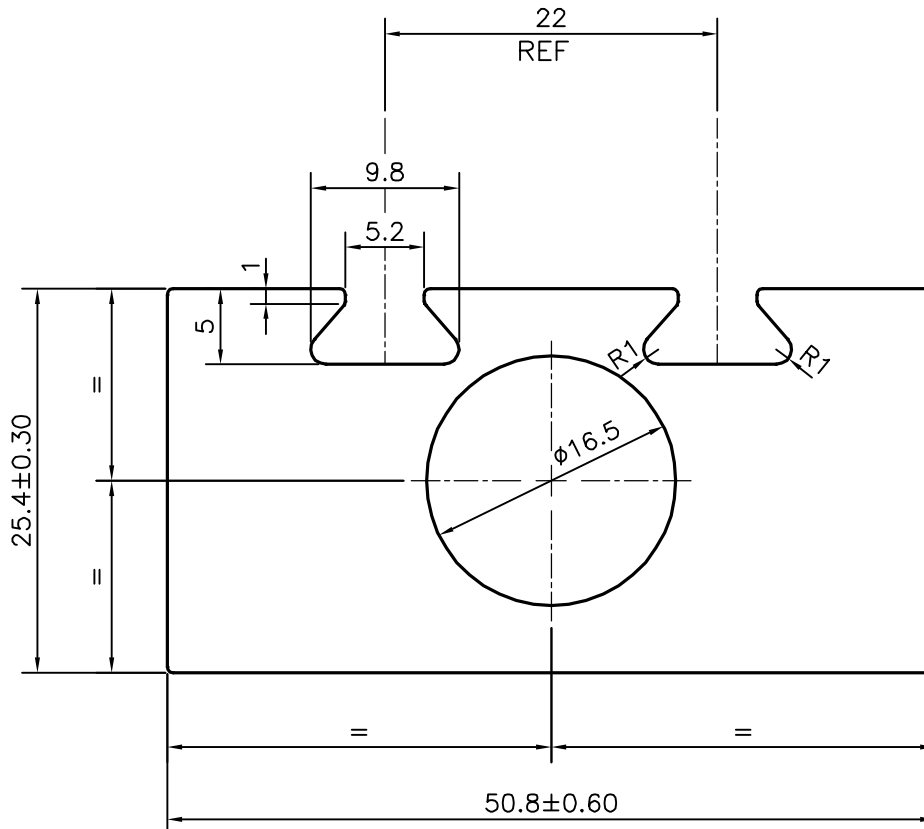

SYMBOL OF QUALITY  
AN ISO 9001 COMPANY

**JINDAL ALUMINIUM LTD.**  
BANGALORE-560073 (INDIA)

	NAME	DATE
DRAWN	J.P.KAUSHIK	29-06-2018
CHECKED		
APPROVED	B.NATARAJA	09-07-2018
SCALE		2:1
AREA mm <sup>2</sup>		1000.403
PERIMETER mm.		181.788
WEIGHT kg/m		2.701
DRAWING No.	SECTION No.	
P-18363	-	
S5915	S5915	
28550	28550	

1. ALL DIMENSIONS ARE IN mm.
2. ROUND OFF ALL SHARP CORNERS WITH 0.40 mm.
3. TOLERANCES WILL BE AS PER IS:6477-1983 , UNLESS OTHERWISE SPECIFIED

PARTY'S NAME NISHAKA PNEUMATICS, THANE

PARTY'S DRAWING No. NP/SV/BODY-001

ALLOY & TEMPER 6005 T6

DESCRIPTION MISC. SECTION