

P-21511-1

28559

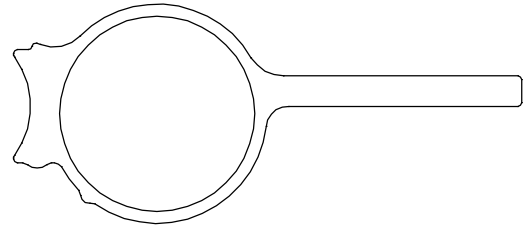

SCALE: - 1:1

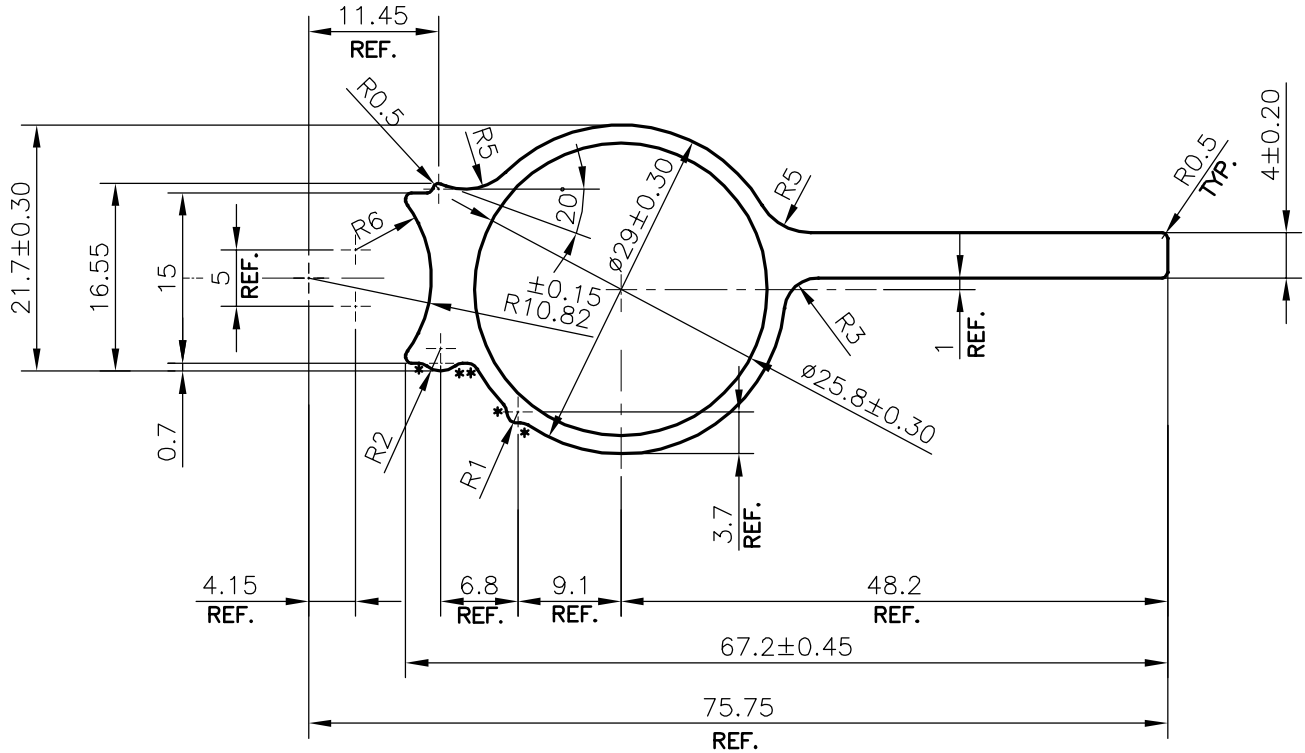

SCALE: - 1.5:1

**RADIUS R0.5mm TYPICAL.**

\* = 1mm RADIUS (5 PLACES)

TOLERANCES ON OVERALL DIMENSIONS OF HOLLOW SECTIONS

UPTO 20.0mm - ±0.30	UPTO 80.0mm - ±0.70	UPTO 180.0mm - ±1.27	1. STRAIGHTNESS=1.7mm/M 2. TWIST=1.7mm/M 3. ANGULARITY= ±2° 4. FLATNESS =0.006xWIDTH
UPTO 30.0mm - ±0.38	UPTO 100.0mm - ±0.80	UPTO 200.0mm - ±1.40	
UPTO 40.0mm - ±0.45	UPTO 120.0mm - ±0.90	UPTO 225.0mm - ±1.52	
UPTO 50.0mm - ±0.52	UPTO 140.0mm - ±1.00		
UPTO 60.0mm - ±0.60	UPTO 160.0mm - ±1.14		



SYMBOL OF QUALITY  
AN ISO 9001 COMPANY

**JINDAL ALUMINIUM LTD.**  
BANGALORE-560073 (INDIA)

	NAME	DATE
DRAWN	DARPAN	19-09-2020
CHECKED		
APPROVED	B.NATARAJA	30-09-2020

- ALL DIMENSIONS ARE IN mm.
- ROUND OFF ALL SHARP CORNERS WITH 0.40 mm.
- TOLERANCES WILL BE AS PER **IS:6477-1983**, UNLESS OTHERWISE SPECIFIED

SCALE	1.5:1
AREA mm <sup>2</sup>	340.136
PERIMETER mm.	170.735
WEIGHT kg/m	0.918

PARTY'S NAME	YOONWOO AUTOMOTIVE INDIA PRIVATE LIMITED., PUNE
PARTY'S DRAWING No.	CGODP01A
ALLOY & TEMPER	3103
DESCRIPTION	AUTOMOBILE SECTION

DRAWING No.	SECTION No.
P-21511-1	-
28559	28559