

P-21668

28565

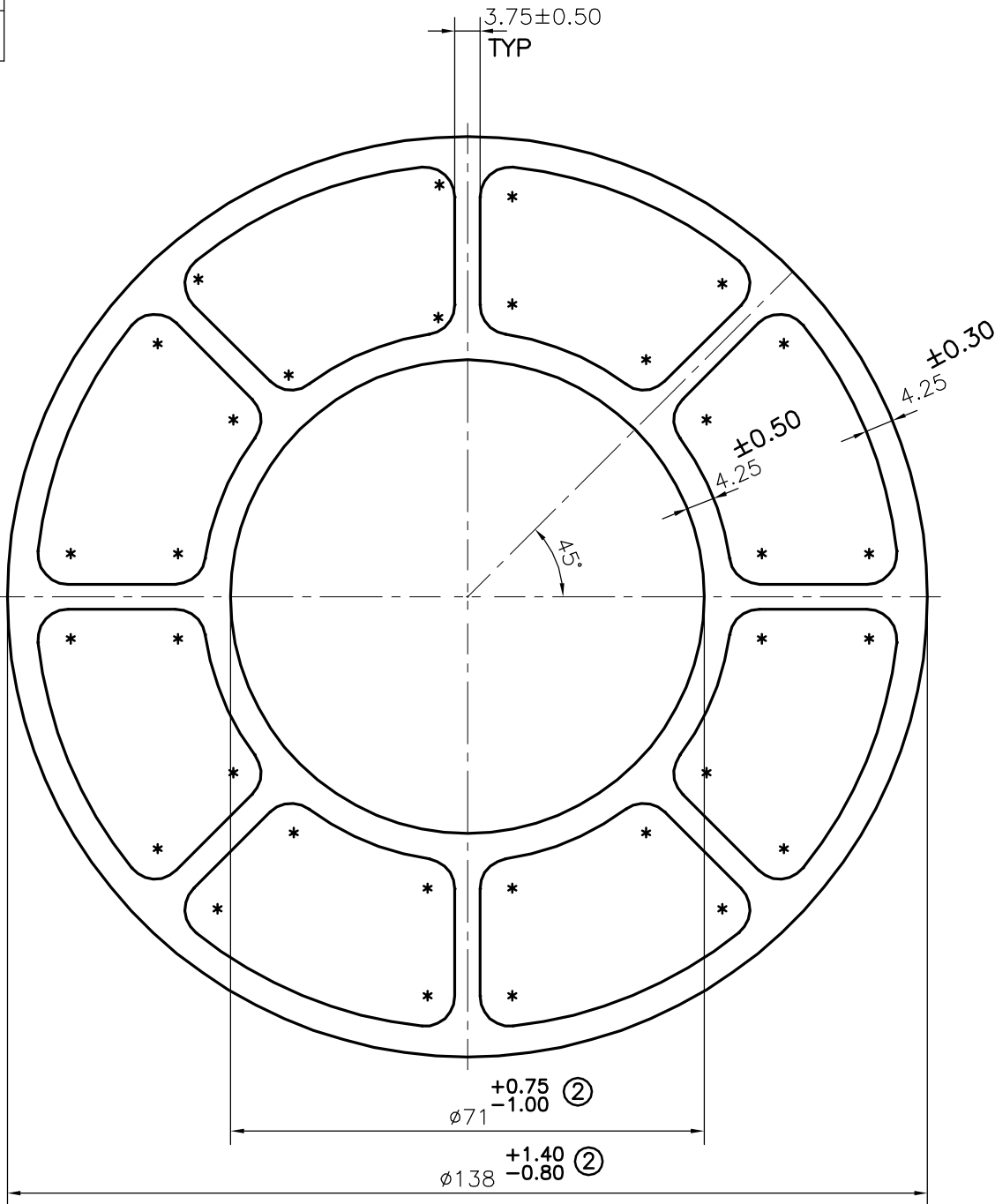

\* = 4.5 RADIUS(32 PLACES)

APPROXIMATE WEIGHT RANGE - 8.936 kg/m TO 10.922 kg/m

ISSUE-2 TOLARANCE CHANGED ON ID  $\phi 71$  FROM  $\pm 0.90$  TO  $\pm 0.75$   
 TOLARANCE CHANGED ON OD  $\phi 138$  FROM  $\pm 1.10$  TO  $\pm 1.40$  DATED-25/11/2020

 SYMBOL OF QUALITY AN ISO 9001 COMPANY	<b>JINDAL ALUMINIUM LTD.</b> BANGALORE-560073 (INDIA)	NAME	DATE
		DRAWN	J.P.KAUSHIK 25/11/2020
		CHECKED	
		APPROVED	B.NATARAJA 02-12-2020
		SCALE	1:1
		AREA mm <sup>2</sup>	3677.336
		PERIMETER mm.	433.54
		WEIGHT kg/m	9.929
PARTY'S NAME	FALCON PUMPS, AHMEDABAD	DRAWING No.	SECTION No.
PARTY'S DRAWING No.	AS PER DRAWING	P-21668	-
ALLOY & TEMPER	6063 T6	28565	28565(ISSUE-2)
DESCRIPTION	MISC. TUBE		