

P-18514

S5950

28576

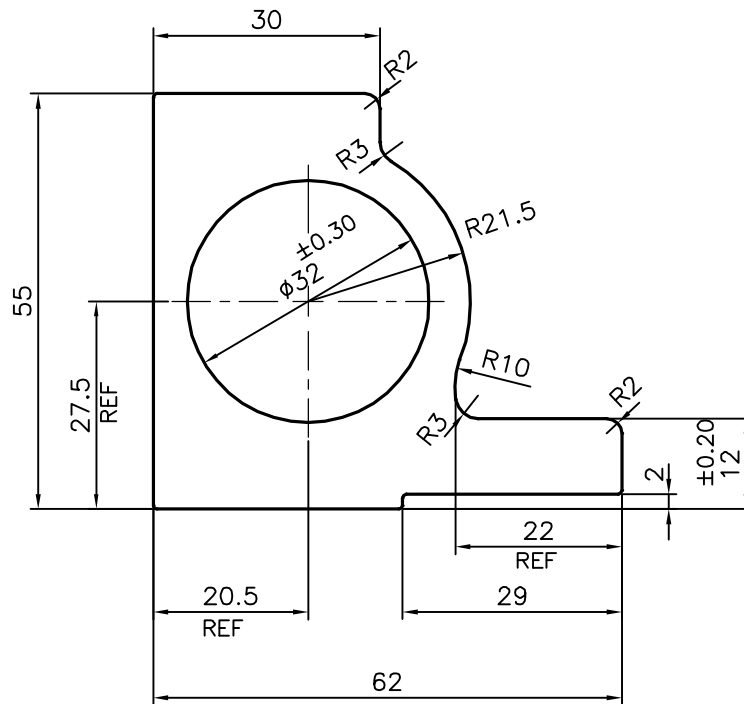

UNSPECIFIED RADIUS 0.5mm



SYMBOL OF QUALITY  
AN ISO 9001 COMPANY

**JINDAL ALUMINIUM LTD.**  
BANGALORE-560073 (INDIA)

	NAME	DATE
DRAWN	J.P.KAUSHIK	02-08-2018
CHECKED		
APPROVED	B.NATARAJA	07-08-2018

1. ALL DIMENSIONS ARE IN mm.
2. ROUND OFF ALL SHARP CORNERS WITH 0.40 mm.
3. TOLERANCES WILL BE AS PER IS:6477-1983 UNLESS OTHERWISE SPECIFIED

SCALE	1:1
AREA mm <sup>2</sup>	1505.093
PERIMETER mm.	224.482
WEIGHT kg/m	4.064

PARTY'S NAME	CONFIDENT DENTAL EQUIPMENTS LTD., BANGALORE	DRAWING No.	SECTION No.
PARTY'S DRAWING No.	R&D Z-15436	P-18514	
ALLOY & TEMPER	63400 WP	S5950	S5950
		28576	28576
DESCRIPTION	BRACKET SECTION		