

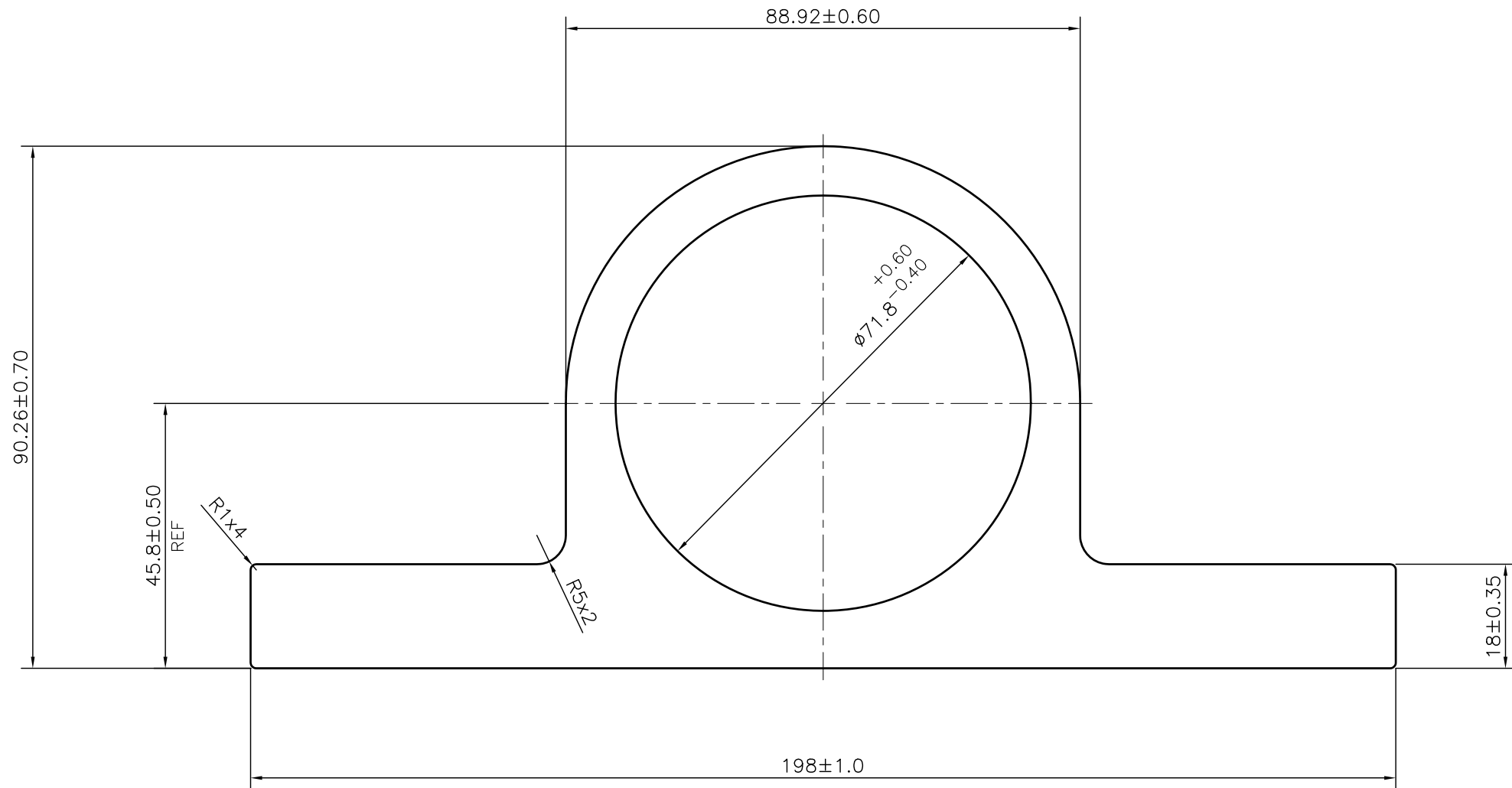

P-21872-2

28599



APPROXIMATE WEIGHT RANGE - 13.507 - 14.042 kg/m

FLATNESS:-0.8 mm

 SYMBOL OF QUALITY AN ISO 9001 COMPANY	<b>JINDAL ALUMINIUM LTD.</b> BANGALORE-560073 (INDIA)	NAME	DATE
		DRAWN	J.P.KAUSHIK 06-01-2021
1. ALL DIMENSIONS ARE IN mm. 2. ROUND OFF ALL SHARP CORNERS WITH 0.40 mm. 3. TOLERANCES WILL BE AS PER IS:6477-1983 UNLESS OTHERWISE SPECIFIED		CHECKED	
		APPROVED	B.NATARAJA 27-01-2021
PARTY'S NAME ANAND NVH PRODUCTS PVT. LTD., GURGAON		SCALE	1:1
		AREA mm <sup>2</sup>	5101.912
PARTY'S DRAWING No. 4121133C1		PERIMETER mm.	532.346
		WEIGHT kg/m	13.775
ALLOY & TEMPER 6061 T6		DRAWING No.	SECTION No.
		P-21872-2	-
DESCRIPTION BRACKET SECTION		28599	28599