

P-3258

S675

7318

28601

Perimeter = 292.208 mm

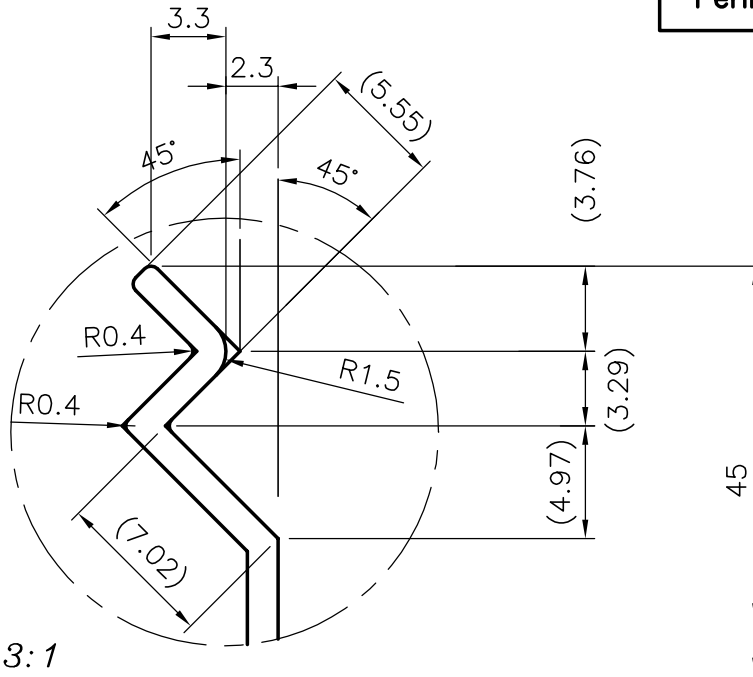

SCALE 3:1

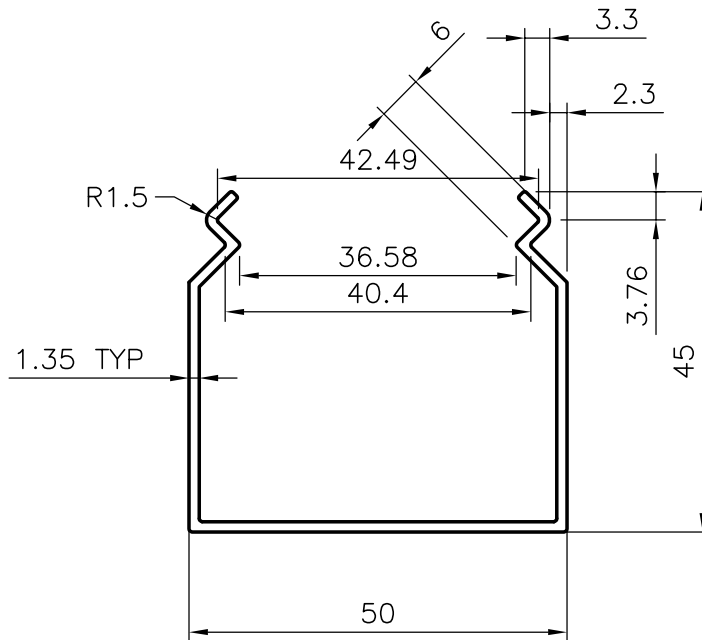

GENERAL WALL THICKNESS 1.35mm



SYMBOL OF QUALITY  
AN ISO 9002 COMPANY

**JINDAL ALUMINIUM LTD.**  
BANGALORE-560073 (INDIA)

	NAME	DATE
DRAWN	SUDIP ROY	29.06.2001
CHECKED		
APPROVED		

1. ALL DIMENSIONS ARE IN mm.
2. ROUND OFF ALL SHARP CORNERS WITH 0.40 mm.
3. TOLERANCES WILL BE AS PER I.S 3965-1981 UNLESS OTHERWISE SPECIFIED

SCALE	1:1
WEIGHT kg/m	0.532
SECTION No.	28601

PARTY'S NAME	POWER GEAR LTD BANGALORE
PARTY'S DRAWING No.	AS PER YOUR DRAWING (6333469/F)
ALLOY & TEMPER	HE9 WP
DESCRIPTION	WIRING CHANNEL

DRAWING No.	28601
-------------	-------